

# Model radio control CARS

ISSUE No. 2

SIX ISSUES PER ANNUM

Price 50p. \$1.00 (US) DM2.50 Fr.F4.50 Glr.2.50 Sw.Fr.2.50



# R/C CARS Ted Longshaw for Service & Experience

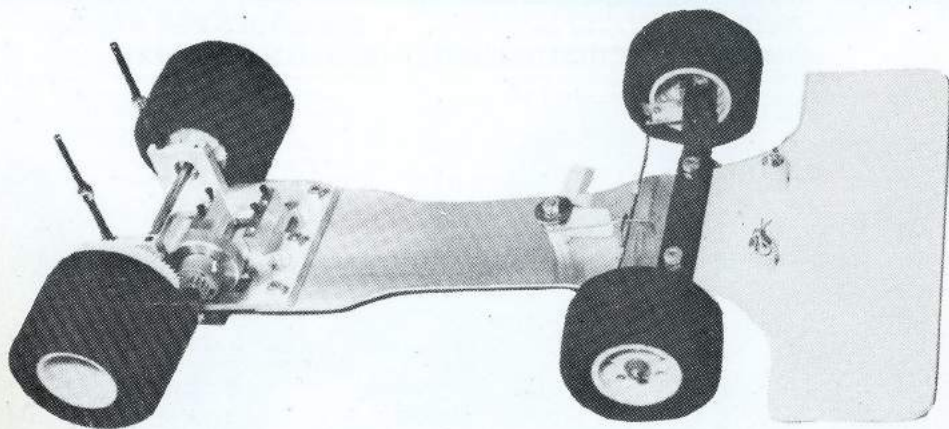

## PB INTERNATIONAL . ASSOCIATED

All (yes all!) ASSOCIATED kits and spares stocked including over 30 bodies : All PB International plus unequalled range of Delta, HRE, Marker, SG : Tyres from all manufacturers plus Ultimara, Parma. Engines K & B, S. Tigre, Veco, McCoy. Body shells 1/8 and 1/12. Radio — Futaba.

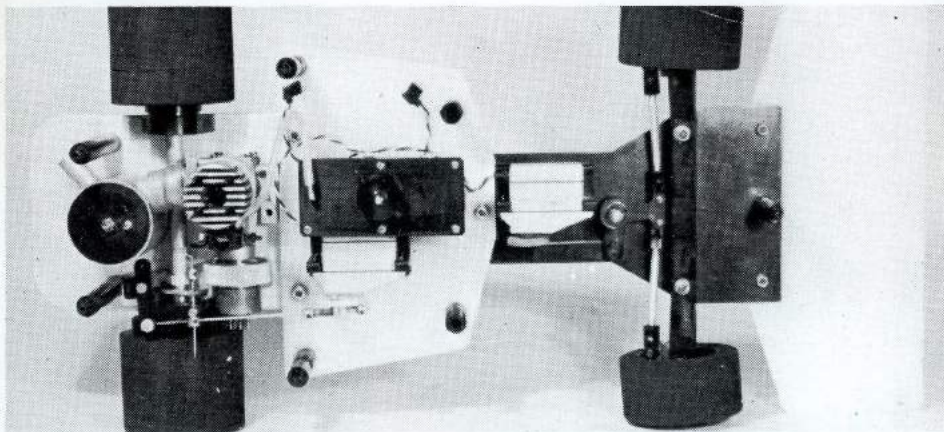

Send for list (50p) or visit showroom at Biggin Hill (appointment only)

Office:

**80 PEPYS ROAD, LONDON SE14 01-639 5080**

radio control

Published by L-D EDITORIAL & TECHNICAL SERVICES LTD., P.O. Box 30 HEMEL HEMPSTEAD, HERTS. HP1 1NL.

# MODEL CARS

Editor: "Dickie" Laidlaw-Dickson

## THE TUMULT AND THE SHOUTING . . .

NOW THAT the euphoria of launching a new magazine, and the pleasure of reading encouraging comments in letters sending money, and the money, has subsided, may I sincerely thank everyone who has been so very generous in their remarks after seeing the first issue, the sixty and more model shops who have given me regular orders in the U.K. plus a wide band of interest and demand from Europe, and valuable advertisement support from home and abroad.

Thanks too to Gene Husting of Associated who has not only sent a RC100 kit for construction and review but taken advertisement space (as if it needed boosting!) and provided photographs and comment to augment Phil Greeno's report. Larry Hibbert Jr. of the U.S. broadsheet RACING/CIRCUITS has very sportingly sent me a file of copies from their issue No. 1, with blanket permission to reproduce with due acknowledgment. Some of their articles on working up engines with minimum equipment are just as valid today for newcomers as when written.

This brings up our solitary (so far) "Dear Pig" letter, criticising Fred Livesey's tuning article. I know the drawings were bad — our tame artist was not available — but the matter is good and practical. I print the letter with Fred's comments and have invited material from our critic. Please do not pull your punches, tell me what you don't like as well as what you do. Some other constructive comment includes: bigger pictures; coloured cover; not trying to cram so much in a single issue . . . and ideas for future articles all of which gratefully noted.

## WHERE TO GET YOUR ISSUES

If your local model shop is stocking RCMC then you are laughing. If not it is up to you to bully him into ordering a minimum of six copies which we will gladly supply at trade terms. Otherwise it is still a matter of sending 60p each issue, or taking out a subscription at £3.50 per year (six issues). We charge for postage ("Outrageous!" was one comment, "with all the money you are making out of me!") but the stamp is 9½d and the envelope nearly 1p . . . We would rather do up a parcel of six or a dozen and let your model shop do the selling.

## CLUBS, CIRCUITS AND CLUB ACTIVITIES

Given time this mag should almost run itself. Already a number of as yet unknown clubs have surfaced and mentioned their existence, previously known only to a select few. We probably have more clubs and permanent, or fairly permanent tracks in this country than any other, but there are still others as yet undeclared. Let us hear from you. Give us details of your activities, the cleverness of your best drivers and builders . . . everything in fact that will stimulate all round interest. In this issue Stew Busby gives a glimpse of the Newbridge picture with practical information as well . . . this could be a model of how to do it.

## IGNORANCE IS NOT BLISS

Every Editor has some sort of a Bee in his Bonnet. Mine is Tyres, but bigger TYRES!!! All that clever stuff with engines, super carbs, fuels, fancy body-shells, but tyres still diecut out of sheet rubber or synthetic like mother making mince-pies! Yes, I have seen them sliced off a hollow rubber tube (some recent SG tyres seem made that way) but this I am

IN THIS ISSUE : WORLD CHAMPIONSHIPS IN CALIFORNIA : CLUB NOTICEBOARD : PUTTING TOGETHER A STOCK CAR KIT : THE NEWBRIDGE SCENE : EUROPEAN CHAMPIONSHIPS AT LYON : STARTERS GALORE : STEERING GEOMETRY — ACKERMAN, CAMBER, CASTER, "TWEAKING" : THE THINGS THEY SAY : RACING IN TRANSVAAL : BITS AND PIECES

**2**

told leads to irregular hard spots. I have seen them rolled round and the butt edges joined with Loctite, Zap or similar . . . again not very satisfactory but saves a lot of rubber. I have seen a few moulded tyres as used for front ends from the American market.

We are probably making as good a range of tyres in the UK as anywhere at present. Certainly, Raydio Tyres are exporting to the continent, and I did hear that Rony Ton has been using them with some success. Raydio Tyres have got a moulding machine in the of-  
fing . . . perhaps Ray Parker is about to make a breakthrough.

What surprises me is that the big tyre boys have not come in with something . . . how about it Dunlop, Avon, Goodyear, Semperit, Michelin. Continental . . . there are enough of you . . . and everyone knows that tyres, like motorbikes, are an addiction . . . once you get to like a make you tend to stick with it.

Very little has been written or researched on tyres in our model field — articles, suggestions, experience will be welcome and very unlikely to have been duplicated anywhere else. I shall be harping on this topic . . .

#### OTHER PEOPLE'S MAGS

In addition to RACING/CIRCUITS and BRCA's, CIRCUIT CHATTER I would thank Lucy Lindre of **Federation Belge d'Automodelisme** for their **FBA NEWS**

*Scratchbuilt Tyrell six-wheeler by Carlos Merseburger of Spain. Body is of fibreglass, heat sink and exhaust stack/silencer also home-built.*

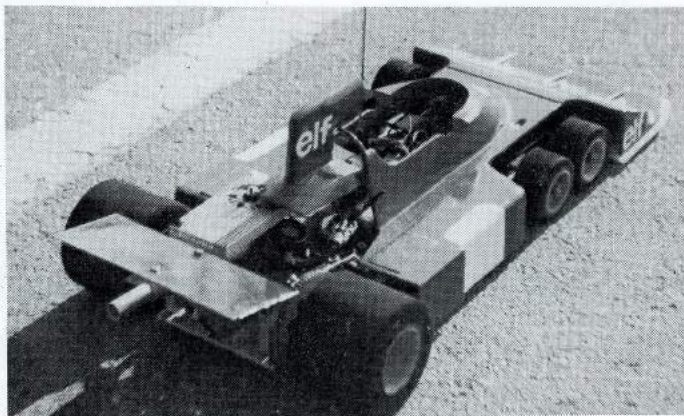

EUROPÄISCHE FEDERATION  
RADIOGESTEUERTER AUTOMODELLE



#### ITALY

Guerrino Stanzani, Via Sacconi 13  
51100-Pistoia

#### Monaco

Aero Club de Monaco  
14 avenue de Fontvieille  
MC MONACO

#### Luxembourg

Guy Blitgen  
21 rue Luc  
G.D. de Luxembourg

Changes of address to note:

I have lifted two delightful cartoons from their columns; also Model Auto Club Heemstede's Editor Gerard J. Hoogeveen for copies of their **1:8 racing journal**, which is rather harder reading but full of good meaty material; and general **modelling and ADEPTE, France**, with excellent W.C. report. Any other national, or club magazine will be avidly read and duly abstracted.

## CLUB & TRACK REVIEW

### Aldershot Model Club (Car Section)

*Secretary:* G. A. Yarborough,  
Middle Watch, Glenville Gardens,  
Tower Road,  
HINDHEAD, SURREY.

PLEASE NOTE name and address of secretary as above, not as published in previous issue. Club is steadily growing in membership with both Formula 1 and Stock Car interests. It is hoped to build a planned circuit on or near existing track at the Parade Ground, H.M.S. Swiftshore, Badshot Lea, Nr. Aldershot.

### Bath — Bristol

Mark Burrell of 65 Hurn Lane, Keynsham, Nr. Bristol, Avon, BS18 1RS would like to hear from interested people who would form a 1/12th scale electric car racing club in the area. There are some excellent venues in the Keynsham district and if an approach made by a suitable group would be amenable to loan and or hire. Mark is fifteen and full of enthusiasm but some adult backing would be appreciated.

### Chessington Radio Car Club

*Secretary:* George Dudman,  
1 Chatsworth Gardens,  
New Malden, Surrey. KT3 6DW

This club appeared as "Surbiton Town Sports Club" in previous issue. Venue is now the R.A.F. Rehabilitation Centre at Chessington, where they have use of a car park with first class surface on Sundays (except for rare occasions when the Centre has a function on that day). Membership stands at thirty-five and on the up, thanks to regular demonstrations at charity fetes. Membership application form on request. Annual fee £2.

### Firebird Model Club (Car Section)

P.R.O.: John L. White,  
29 Barton Drive,  
Hedge End,  
Southampton.

Whilst also devoted to boats and aircraft Firebird M.C. has a growing car section with ten Formula cars and five stockers. Meetings held every third Thursday in the month at the Fire Station, Botely. Car practice currently seven days a week! At present we use a variety of smooth car parks, but negotiating with local

authorities for a permanent site. Recently put on a show with Keith Plested of PB Products with the help of BBC Radio Solent to publicise the need for a permanent circuit in the Portsmouth — Southampton area, with special emphasis on the spectator appeal of the sport.

### Haywards Heath R/C Stock Car Club

*Secretary:* Pete Crawley,  
16 Turners Mill Road,  
Haywards Heath.  
(Tel. Haywards Heath 53595),  
Sussex. RH16 1NN.

Now two years old and covers all forms of oval racing, stock cars, hot rods, midgets and even bangers. Have use of a car park — usually Sunday mornings. Official race meetings once a month for prizes and trophies. Membership is invited to join their merry bunch and race on a fast tight track.

Will be holding Sussex Open Stock Car Championship (R.S.C.A. approved) in November. Write secretary (SAE) for details.

### Keighley and District M.E.S. (Stock Car Section)

*Secretary:* Peter Humphrey,  
304 West Lane, Keighley,  
West Yorkshire. BD21 2RT.

Club track is at Marley in the grounds of the Keighley and District Model Engineering Society, is constructed of fine tarmac, with crash barrier of polyprene tubing. Spectator barriers will also be erected. Racing will commence next season as work not quite complete. Affiliated to R.S.C.A. so official meetings will be run. Enquiries to secretary with SEA please.

### Taunton Radio Auto Klub (T.R.A.K.)

*Secretary:* Mike Lewis,  
3 Longmead Close,  
Hoveland Park (Tel: 85543).  
Taunton, Somerset.

The club was formed on May 1st this year and with the permission of the local authority uses a car park site of an area approximately 90 yards by 30 yards. Meetings each Thursday evening and every other Sunday. Membership comes from a wide catchment area including Bath and Weymouth but is still relatively small so that new members will be

welcomed. Hope to participate in a r/c car demonstration at Yeovil as part of Duckham's Motoring Cavalcade.

#### Midland Electric Radio Car Club

Secretary: Tony Davenport,  
200 Windmill Road,  
Coventry. CU6 7BE.

Races regularly at Wolvey Village Hall (A46 North of Coventry and M6 Junction 2) and 1st and 3rd Thursdays of the month at 8 p.m. Minimum of rules (1) Standard motors (2) Max of 6 batteries (3) 1/12th scale. Information from Tony — or as he says, just turn up to race!

#### Strathclyde Model Auto Club

Secretary: Mike Green,  
35 Greenways Avenue,  
Paisley,  
Renfrewshire. PA2 9NS.

Have one permanent track going, and are negotiating for use of three other sites, so that varied meetings are held locally without expensive travelling costs. New members welcome; prospects should write to Mike Green as above.

#### Portsmouth R/C Car Racers

Secretary: K. Plested  
6 Record Road,  
Emsworth, Hants.

#### Wirral Model Car Club

Secretary: R. H. Vick,  
74 Grampian Way,  
MORETON (Tel. 051677 9040 (evenings)  
051 647 6080 (days),  
Merseyside.

A recently opened club their track is at West Kirby in the Wirral Peninsula, approximately 176 yards long and tarmac surfaced. All classes of car are catered for, and beginners are more than welcome. Prospective members should contact secretary as above.

#### Yareside Model Car Club

Secretary: Peter W. Robbins,  
Home Farmhouse,  
Home Farm,  
Somerleyton,  
Lowestoft. NR32 5PR.

At present using a private car park in Lowestoft. Eager to increase membership so get in touch with secretary! Currently running Mardave Stock Cars, but several members moving over to Formula and Sports/GT with Mardave and PB. Enthusiasts from any part of the country would be welcome at their meetings.

#### Coventry Radio Stock Car Club

Secretary: R. E. Dixon,  
123 Arbury Avenue,  
Coventry.  
(Tel. Coventry 86349).

#### Transvaal Radio Auto Club

Chairman: Jeff Barclay,  
31 Nestadt Street,  
Rynfield, BENONI,  
Transvaal, South Africa.

#### Liverpudlians Forward!

Would-be club anxious to start mini-Aintree should get in touch with Mr. P. M. Noone, 18 Radstock Road, Elm Park, LIVERPOOL 6, who wants to form a club.

#### New Hull Area Electric R/C Club

Anyone interested contact Dick Winder on Hornsea (04012) 2378 evenings only. An indoor tarmac track is available.

**ELECTRIC CAR CLUBS . . .** The electric car explosion continues to generate new interest and clubs! About 20 avid car racers have been meeting on the first and third Thursdays of each month in Wolvey Memorial Hall, Leicestershire. The location is no surprise . . . this is indeed Lectricar country! Yet, supporters from the Radio Stock Car Association's members also contributed to the club, which began in December of 1976.

Lectricar's Escort RS, Porsche 911 and 914's dominate the circuit. A new Lectricar body, the Porsche 916 (supplied with body pack for conversion) has been racing at Wolvey, and is now available in the shops.

While the club is not formally organised, rules have been agreed upon by those who race each meeting; engines must be left "standard", running on a maximum of six cells. All cars are 1/12 scale. Modifications are allowed, however, on tyres.

As with several other current electric car clubs, an evening session consists of competitive heats (5 minutes each) which determine the participants for "semi's" and the final race. An extra attraction of the Wolvey Hall club: prizes are awarded to the top three racers of the night in the form of discount vouchers from Lectricar (£1, 75p, 50p). All electric car enthusiasts are welcome! For further details, contact Phil Arnold in Coventry (tel. 0203 74385).

The electric car club at Alexandra Palace in North London has fortunately received a reprieve! The Greater London Council has decided to postpone the previously planned roof repairs, so the Ally Pally club will keep its home until further notice. New car bodies are appearing all

the time, but the Bolinks, Jerobees and Lectricars continue to dominate the scene.

On Saturday, August 27th, club members were invited to exhibit their racing skills at a local fair and exhibition held at the Palace. From 12.00 to 6.00 p.m., enthusiastic spectators watched as demonstrative races were held throughout the afternoon. It seemed to be a good "boost" for electric car racing, a fact reflected by the interest shown and questions asked by spectators who previously hadn't been acquainted with "electrics".

The club is now in the process of being formally organised, due to interest expressed by the present Ally Pally racers. (More news on that in the next issue!) Yet even when an "official" club, spectators and visiting racers will be welcome for a small fee. For now, however, the club continues to meet on specified Wednesdays. For details and club dates, contact Dave Rogers in London (01-804-1183).

#### RADIO STOCK CAR ASSOCIATION NEWS

TREASURER DAVE WRAGG, 1 Bignal Drive, Leicester Forest East, Leicester, LE3 3QF has now also taken over the job of secretary, following resignation of A. Whitehorn at the recent AGM. Correspondence should be addressed to him or to Chairman Bob Webb, 202 Treherne Road, Radford, Coventry, CV6 3DW.

Coventry Stock Car Club has agreed that any RSCA member will be allowed to race at any of their club meetings in the future. RSCA members not officially Coventry Club members will not, however, take part in the consolation or final, as this would upset grading system.

#### ELIGIBILITY

RSCA IS open to all makes of stockcar provided they conform to the construction rules. In the case of KeJon cars, for example, the rear bumper as standard is ½ in. higher than laid down, but if an extra bumper ½ in. wide is added below the original, so that the height of the new bumper is 2 in. from its centre to the ground, the car becomes acceptable or "legal"

#### RSCA "WORLD" CHAMPIONSHIPS

THESE TOOK place on 25th September at Leicester and will be subject of report by "our man on the spot" Pete Cawley of the Sussex Stock Car Club in our No. 3 Issue.



#### LOK Modellers Club, POLAND

Jan Warczak of ul. Zawiszy Czarnege 1, 81-374 Gdynia, Poland writes of his country's r/c model car activities. His club LOK specialises in model cars and is a leading club in Poland. He has been Polish champion twice, and fellow club members have won numerous prizes. Interests are in GP and GT racing. Will be giving us information on model matters in his part of the world and would welcome correspondence with other clubmen everywhere. (Jan with car above).

#### BRITISH RADIO CAR ASSOCIATION

Chairman: K. G. Plested, P.B. Products, Downley Road, Havant, Hants. Tel. Havant 71774. Evenings Emsworth 2607. Secretary: T. H. Martin, 7 The Green, Werrington, Peterborough. PE4 6RT. Telephone (0733) 72114.

#### YOUR R/C LICENCE!

The Home Office, Radio Regulatory Dept., Waterloo Bridge House, Waterloo Road, London S.E.1. (Send for form: costs £2.40 for five years).

# WORLD R/C CAR CHAMPIONSHIPS

THORP RACEWAY : POMONA : CALIFORNIA

WITH 107 total entries, 38 from Europe, two from S. Africa, two from Japan, two from Hawaii and no less than 63 Expert Drivers from USA the recipe for the first ever World R/C Car Championships looked good.

The venue, Thorp Raceway, Pomona, California would be an unknown quantity for the foreign entries and probably 50 per cent of American drivers. Our only indication of track shape and condition would be a small sketch of the track which appeared in the American car magazine "Racing Circuits" and one simple line from the organisers saying traction good, bring all the horsepower you can carry. Well we would arrive with nearly a week available for practice before qualifying and the three main finals so we would have plenty of time to get things right, or so we thought!

We arrived at Thorp Raceway late Sunday afternoon for just a LOOK at the track but with Franco Sabatti and Ronnie Ton and a few of the fast American drivers already practising like mad it was too

much of a temptation and within half an hour every one of the British team was hammering around, Thorp intent on blowing an engine or wearing a car out as soon as possible or so it seemed.

Initial impressions of the track were of fantastic traction and I mean fantastic traction, the like of which none of the British team and most of the European and foreign competitors had ever experienced before, the grip available was so good that it was practically impossible to spin out in a turn regardless of how much power you had and the power you had available also became very relevant indeed.

With Phil Booth, Dave and Debbie Preston, Ted Longshaw using highly re-worked S/Tigre x 21's, Phil Greeno, Keith Plested and Mike Wickens running K. & B. 21's and Doug Blair using an OPS 21 it was quite interesting to see which engine delivered the necessary horses.

*On this and next page are shown a goodly proportion of the hundred plus entries in a wide variety of colour schemes even if mainly K & B powered within!*



Well from the very beginning it was quite obvious that the K. & B. 21 suited this track with all its bottom end torque that at last could be put down and used. The Super Tigre's x 21's just could not match that K. & B's acceleration out of the bends and it wasn't long before all the British Team with the exception of Doug Blair were running K. & B. 21's. This need for acceleration out of the bends became apparent when one looked at the top USA competitors, especially the Associated Works team (all ten of them). They were using K. & B. 21's all right but with a 6:1 final drive — yes 6:1. "It's not fair, PB don't make a 6:1 gear ratio" was one of the GB team's remarks; another was: "They're using a Perry 61 pumper carb on a 3.5cc motor without a pumper and it works". More to the point was that the associated works drivers were super fast. Bill Jianas and Chuck Phelps were regularly cutting laps around the 17 seconds mark while as a comparison Phil Booth and Ted Longshaw were regularly lapping in the 19's with an occasional lap in 18 sec. mark but when Bill Jianas went out and lapped with best time of 16.7 secs. the writing was on the wall.

The competition itself was a three-day event with the Saturday and Sunday being devoted to qualifying only. Each competitor was allowed only one ten minute qualifying heat each day plus five minutes' practice before hand. The best heat time would then count towards the finals. The

*Winner Butch Kroells with happy victory smile. A man with the mark of genius — an infinite capacity for taking pains!*

**STORY & PICS BY OUR MAN ON THE SPOT PHIL GREENO + ADDITIONAL PICS BY THIRD MAN GENE HUSTING AND HIS OWN ACCOUNT OF A MAIN RACE . . . MORE ON CHAMPS NEXT ISSUE.**



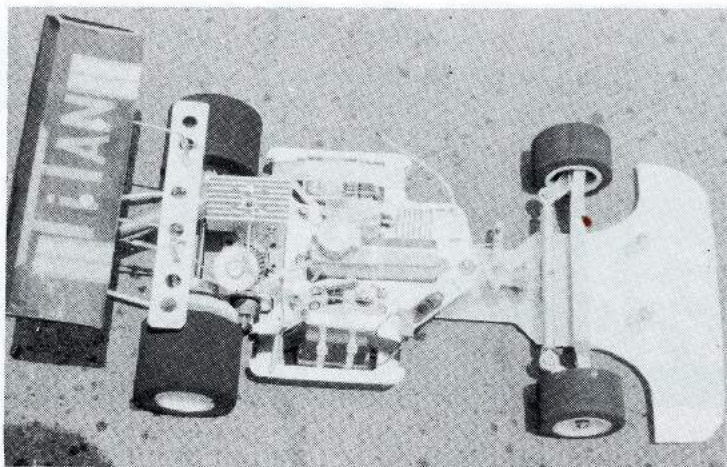

Bob Titterington's Titan, basically an Associated car (2nd in C Main).

finals or "mains" as our American friends called them were split into three groups. The 'A' Main was for the top ten qualifiers, the 'B' Main for qualifiers 11-20, and the 'C' Main for qualifiers 21-30. Obviously with 108 competitors of the world's best drivers (of the 63 USA entrants only expert drivers were allowed to compete) getting into the top 30 was going to be difficult to say the least.

Day one of the qualifying saw problems for most with Phil Booth and Dave Preston both suffering engine problems and failing to record times; Phil Greeno had a terrific start in his heat but was called to a re-start after the timing gear failed to work. After the re-start he suffered several very bad shunts to retire with body work damage. Ted Longshaw decided that 20 minutes before his qualifying heat was a good time for a ride in his 22 foot three-ton Ford LTD Battleship in search of a pair of sunglasses, only to arrive back at the track while his heat had already started. Lucky for Ted he actually arrived back before the time his heat was due to start, the time table actually running ahead of schedule. He was allowed a second chance the next day. All was not gloom though as Debbie Preston drove beautifully with a super smooth drive to qualify 19th overall at the end of the first day.

The second day of qualifying saw some better driving for the British and European entrants. All the British drivers with the

exception of Mike Wickens, managing to have trouble-free runs and complete all 30 laps of the qualifying heats. At the end of the day everyone waited patiently for the results of the top 30 qualifiers. The top ten were total USA benefit with nine West Coast divers making it with Bill Jianas being top qualifier with a fantastic run of 542.6 secs. for 30 laps, Chuck Phelps (556.9), Matt Azzara (561.9), Rich Lee (561.8), Gene Husting (569.0), Jeff Rold (569.7), Arturo Carbonell (571.8), Mike Rowland (575.5), Butch Kroells (576.1) and Gary Buriani (580.0) make up the 'A' Main top ten.

The 'B' Main saw Garry Grosenbacher (USA) (578.0), Bill Campbell (USA) (589.4), Rick Davis (USA) (590.5), Debbie Preston (GB) (590.9), the fastest European qualifier, a school-girl and only 14 years old — a really fantastic achievement; Reiner Dosch (Germany) (592.00), Bill Coalson (USA) (592.00), Dave Dawson (USA) (592.8), John Thorp (593.00) (USA), Phil Booth (GB) (596.6) and Franco Sabattini (Italy) (601.00).

The 'C' Main saw M. Queller (USA) (601.3), D. Stewart (USA) (602.2), J. Kimbrough (USA) (603.5), J. Pretorius (S. Africa) (603.5), B. Welch (USA) (603.7), C. Hallam (USA) (604.6), T. Longshaw (GB) (605.2), R. Curtis (USA) (605.5), G. Kyes (USA) (606.1), B. Tittering (USA) (606.9).

The remaining drivers were just not fast enough and would have to be spectators for the three finals on Monday, 4th July.

Monday morning saw last minute adjustments made to most cars after the

early morning practice session.

In the British camp Phil Booth, Ted Longshaw and Debbie Preston had made it to the finals but Phil and Ted both felt they were down on power and were worried that their engines would not last the 100 laps finals in the heat of Southern California. Phil Greeno who without a doubt had one of the quickest K. & B. 21's outside the American Team kindly lent Phil Booth his best engine for the 'B' Main and Ted Longshaw quickly snapped up Phil Greeno's No. 2 K. & B. to keep in the running.

Young Debbie Preston who had been driving beautifully all week had a very strong but perfectly standard K. & B. 21 in her PB International and felt quite confident as she was.

### 'C' MAIN

The first event of the day was the 'C' main run over 100 laps. Roger Curtis (USA) took an immediate lead from John Pretorius (SA), Jay Kimbrough (USA), Bob Tithington (USA), Ted Longshaw (GB) with the rest of the pack in close pursuit. After the first fuel stop it was Curtis followed by Longshaw, Welch, Kimbrough, Queller, Pretorius, Hallam and Tithington. By half distance Roger Curtis was building up a sizeable lead with Bob Tithington up in second place, Ted Longshaw in third, and that was the way it stayed until the finish. Roger Curtis won by over ten laps, Bob Tithington second, and good old Ted Longshaw in third.

### 'B' MAIN

'B' Main was over 110 laps and for 11/20 placed qualifiers. It was somewhat more interesting with four Europeans and six Americans making the numbers. After two jump starts they got going cleanly with Phil Booth in the lead followed by Davis, Grosenbacher, Preston and Dosch. After 25 laps Grosenbacher was in the lead just from Phil Booth and Davis, and it became apparent then that if the times between refuelling could be stretched a real advantage could be gained. Most of the American drivers were re-fuelling after only 5½ minutes, whereas Phil Booth refuelled at 6½ minutes. At half distance Phil Booth took the lead again and stayed there to the end. Gary Grosenbacher was second and young Debbie Preston a fantastic third. Reiner Dosch of Germany was sixth, Franco Sabattini of Italy 8th; after stripping a gear cog and then blowing his engine. Phil Booth's win in the 'B' Main was a terrific result considering the opposition and track conditions. Debbie Preston also drove superbly and can rightly be classed as the fastest lady driver in the world.

### 'A' MAIN

The final event of the day was the 'A' Main for the World Champion driver, with

*Typical track picture. Note pits, drivers' rostrum, "plow discs" to deter corner cutting and those "rideable" wooden walls!*



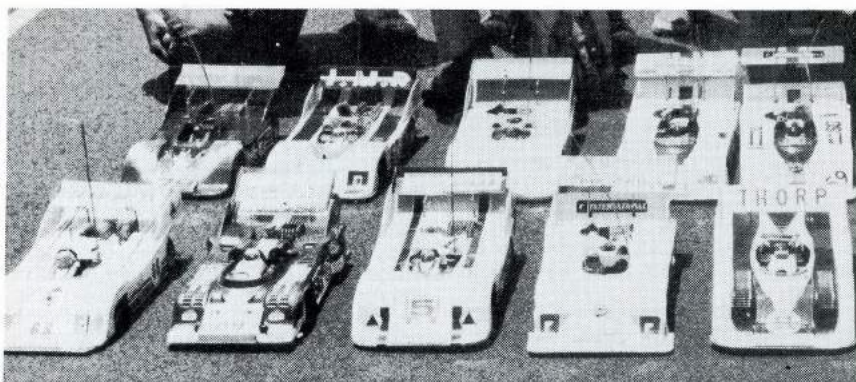

**A Main** left to right (back) Buriani : Rowland : Rold : Kroells : Jianas, (front row) left to right: Azzara : Husting : Phelps : Lee : Carbonell.

the top ten qualifiers (all USA) fighting it out for the title. It seems therefore a suitable occasion to pass over race report to Associated Chief Gene Husting (who came third):

Cars were flagged off to a perfect start with Butch Kroells taking the lead. I was right behind Butch, and Butch opened up a lead as I too started to put some distance on the other cars. About the 10th lap a red, white and blue car was coming up on me — it was Bill Jianas who passed me and took over 2nd. About lap 20 Bill caught Butch and took over lead; two laps later on his pit stop the engine died and he lost two laps. Butch had realised in his qualifying drive that his car was a lot easier to drive and faster if he didn't use lock up brakes. His car was perfect . . . just plain going fast and looking good. I was still holding 2nd when Bill passed me and Butch and then me again to take over 2nd, but his engine died again in the pits . . . another two laps. After about 60 laps, Butch had a one lap

lead. I was still 2nd, but Mike Rowland, Matt Azzards and Rich Lee were right behind on the same lap. Here came the red, white and blue car to pass me again. With 110 laps down and ten to go, Butch now had a two lap lead. Jianas passed me again to take over 2nd place.

On the last lap with only three corners to go Mike Rowland passed me, but I re-passed him in the next corner as Butch Kroells took the chequered flag with Bill Jianas 1½ laps down in 2nd, myself 3rd.

Other European placings: 33 Phil Greeno (GB); 40 Dave Preston (GB); 41 Frank Cromberge (Holland); 42 J. P. Ruchat (Switz.); 45 K. Plested (GB); 50 Mares (Italy); 55 K. H. Will (Germany); 60 D. Blair (GB); 61 H. Sukkel (Holland); 63 E. Brem (Switz.); 64 Emmisberger (Switz.); 66 S. Agostino (Italy); 69 Bo Japlin (Sweden); 71 Sommgraver (Switz.); 75 U. Franke (Switz.); 77 G. Stanzani (Italy); 79 U. Bisi (Italy); 80 W. Collina (Italy); 82 R. Sahlberg (Sweden); 86 H. Muller (Switz.); 89 E. Bopp (Switz.); 92 FvHelden (Holland); 93 K. Urs (Switz.); 94 Krusberg (Sweden); 97

**'A' MAIN**

Place	Name	Laps	Qual. Time	Country	Car	Engine
1	Butch Kroells	120	576.1	USA - CA.	Associated	K & B
2	Bill Jianas	118	542.6	USA - CA.	Associated	K & B
3	Gene Husting	117	569.0	USA - CA.	Associated	K & B
4	Mike Rowland	117	575.5	USA - CA.	Associated	K & B
5	Rich Lee	116	561.8	USA - CA.	Associated	K & B
6	Matt Azzara	116	561.8	USA - CA.	Associated	K & B
7	Chuck Phelps	112	556.9	USA - AZ.	Associated	K & B
8	Jeff Rold	112	569.7	USA - CA.	Magnum	K & B
9	Gary Buriani	41	580.0	USA - CA.	Associated	K & B
10	Arturo Carbonell	34	571.8	USA - FL.	Delta	?

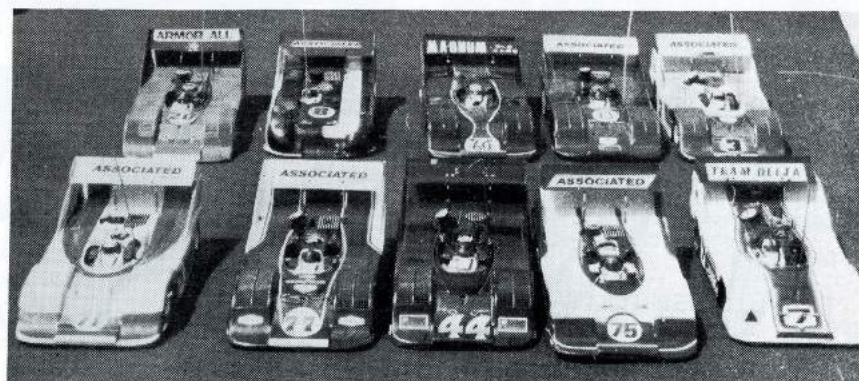

**B Main**, left to right (back): Davis : Dawson : Grossenbacher : Booth : Preston, (front row): left to right: Coalson : Sabattini : Campbell : Dosch : Thorp.

S. Anderson (Switz.); 101 R. Persson (Sweden); 103 H. Crispin (Sweden); 106 R. Ton (Holland); 108 P. Rigot (France).

**'B' MAIN**

1	Phil Booth	110	596.6	England	PB	K & B
2	Gary Grossenbacher	109	598.0	USA - AZ.	Associated	?
3	Debbie Preston	106	590.9	England	PB	OPS
4	Bill Campbell	103	589.4	USA - MO.	Delta	?
5	Dave Dawson	101	592.8	USA - IN.	Delta	K & B
6	Reiner Dosch	92	592.0	Germany	PB	K & B
7	Bill Coalson	90	592.0	USA - MO.	Delta	?
8	Franco Sabattini	60	601.0	Italy	SG	S. Tigre
9	Rick Davis	55	590.5	USA - MI.	Scratchbuilt	?
10	John Thorp	40	593.0	USA - CA.	Thorp	K & B

*A lovely life! Messrs. Booth, Blair, Plested and Preston toy with their cars by the poolside!*

*ON THE COVER: That man again! Phil Booth, B Main winner and top man from Europe with his PB International.*



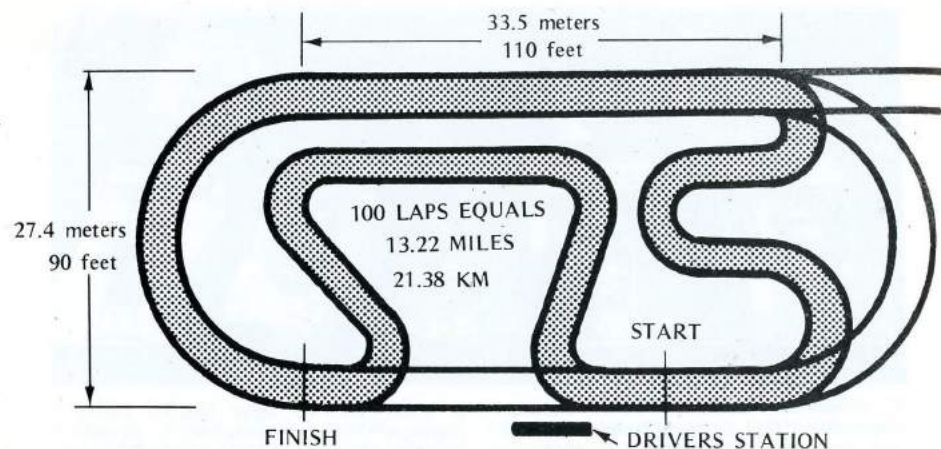

#### 'C' MAIN

1	Roger Curtis	100	605.5	USA - CA.	Associated	K & B
2	Bob Titterington	89	606.9	USA - CA.	Titan	K & B
3	Ted Longshaw	87	605.2	England	PB	K & B
4	Mike Queller	85	601.3	USA - TX.	Delta	K & B
5	Bob Welch	80	603.7	USA - WA.	MRP	K & B
6	Johan Pretorius	73	603.5	S. Africa	Associated	K & B
7	Chuck Hallum	51	604.6	USA - CA.	HRE	K & B
8	Jay Kimbrough	41	603.5	USA - CA.	Associated	K & B
9	Don Stewart	8	602.2	USA - CA.	J-Car	K & B
10	Gary Kyes	DNS	606.1	USA - CA.	MRP	?

Typical Team Associated works car (Chuck Phelps). Note latest Associated disc brakes, McCoy silencer and quick action spring filler cap much admired by the European contingent (PB might even make some!).

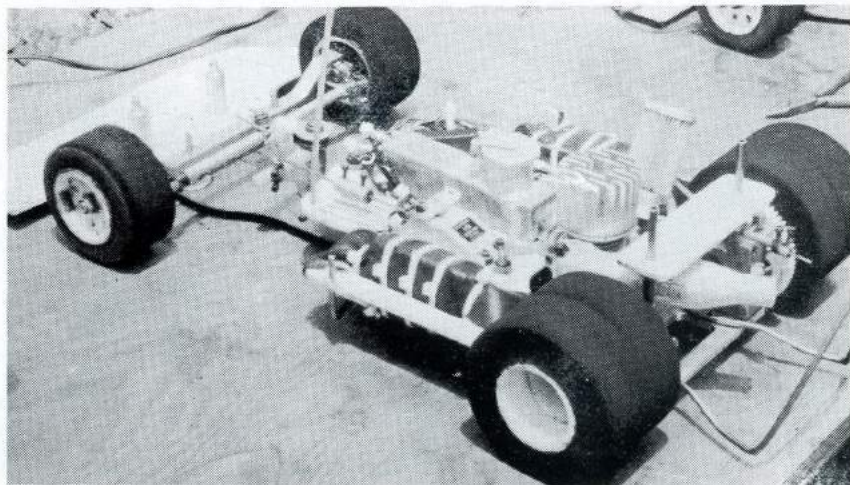

# 308

#### RADIO CONTROL CAR KITS

Associated RC 100	£89.95
Associated RC1	£59.90
Associated RC2	£34.95
Kejon Stock Car	£29.50
Mardave Formula 1	£21.50
Mardave Saloon	£21.50
Mardave Stock Car	£21.50
P.B. Dual	£29.18
P.B. Expert Competition	£56.61
P.B. Expert S.T.D.	£40.23
P.B. International Comp.	£75.00
Lectricar the silent car	£44.87

We have spares and accessories for all the above car kits as available.

#### TWO-FUNCTION RADIO CONTROL EQUIPMENT

Skyleader Clubmate 2 with dry batteries and 2 SRC1 servos	£70.72
Skyleader ditto with re-chargeable Deacs	£80.92
Skyleader Clubman Super with 2 SRC1 servos	£102.91
Skyleader SRC1 servo	£17.97
Futaba Medallion 2 with 2 servos and dry batteries	£63.50
Futaba Twinstick with 2 servos and dry batteries	£72.00
Futaba Steerwheel with 2 servos and dry batteries	£72.00
Futaba Twinstick with 2 servos and re-chargeable Deacs	£100.00
Futaba Steerwheel with 2 servos and re-chargeable Deacs	£100.00
Futaba 16M servo	£18.50
Futaba Electric speed control	£39.00
Sanwa Mini Propo with 2 servos with dry batteries	£54.95
Sanwa Mini Propo with 1 servo and speed controller	£54.95
Sanwa 2F with 2 servos and Deacs	£102.50
Sanwa Micro Servo	£19.50
MacGregor Digimac 2 with 2 servos and dry batteries	£52.50
O.S. Cougar 2 MKII with 2 servos and Deac batteries	£70.04
Micro-Mold 2 function with 2 servos and dry batteries	£69.95

We accept Quad Bonds, Hobbycard and Paybonds as well as Access and Barclaycard. Visitors from overseas can pay in any travellers' cheques or negotiable foreign currency. Overseas visitors are especially welcome at "308" and our shop is only two minutes' walk from Holloway Road Station on the Piccadilly Underground Line.

Our MAIL ORDER Department will send any items advertised by us anywhere in the World to which normal postal services are available.

Telephone orders for payment by Access and Barclaycard always accepted.

## HENRY J. NICHOLLS & SON LTD

the modern model shop

308, HOLLOWAY ROAD,

Established 1946 LONDON, N7 6NP. TEL: 01-607-4272

Now that we have been able to double our sales space at "308" we can carry as comprehensive a stock for the R/C car enthusiast as we have done for many years for Aeromodellers. Here you will find a fine display of all the most popular kits, engines and R/C equipment in cheerful surroundings. With our expanded premises arranged in two sections, Cars (and Boats) are separated from the Aircraft and we have arranged things this way because our customers prefer it. Most important is the fact that the world-renowned reputation of "308" for giving unexcelled service will be maintained in all departments.

#### R/C CAR ENGINES

HB 20 with silencer	£24.50
K & B 21 with silencer	£47.50
O.S. 20 with silencer	£25.97
Super Tigre 19 ABC car	£36.50
Super Tigre X21 ABC car	£40.87
Veco 19 incl. silencer	£24.50

We stock heat sink heads for most R/C car engines.



# CHALLENGER

Swedish R/C Racing Equipment

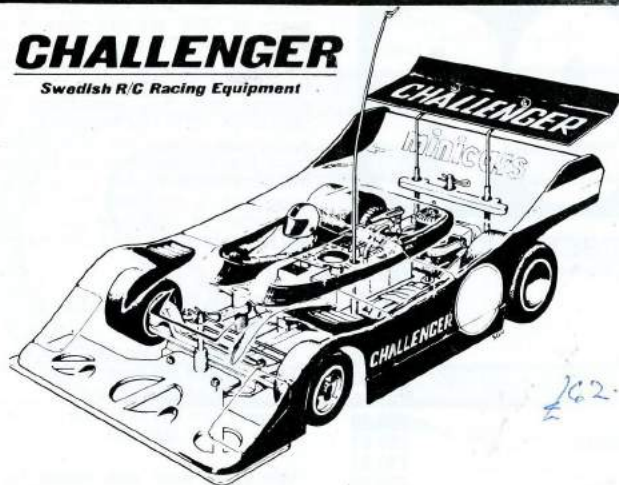

Car kit no. 200 Price 550:— sw. crown/\$127:—

The Challenger, which has been under development for several years, is the result of a new thinking in 1/8 scale radio controlled car technology.

All major parts of the car are constructed in injection moulded delrin, nylon and lexan.

The result is a car which is extremely easy to build without any need for tooling on any parts of the car. CHALLENGER features a one piece power pod with sealed ball bearings for the rear axle.

The power pod has a built in large volume silencer which result in a low noise level when driving.

A powerful brake giving a smooth braking force is located inside the right wheel hub and will keep free from oil and dust. Aluminium flywheel, a two piece clutch shoe and ball raced clutch bell gives smooth driving under all conditions.

The front end assembly features a zero steering. Illustrated mounting instructions makes the mounting of the car easy.

Contains: Chassis, powerpod, rear ball bearings, wheels, front end, body mount, brake, exhaust manifold, front bumper, wing, servoarms, override, linkage kit, servo mounting tray, antenna tube, servosaver, and illustrated mounting instruction.

100 Ligier Sport body with driver in ABS	sw. cr. 70:—	/ \$16.50
001 Chassis in moulded baulen	sw. cr. 15:—	/ \$ 3:—
002 Power pod with built in silencer	sw. cr. 46:25	/ \$10.90
031 Front bumper with three hole fixing	sw. cr. 21:—	/ \$ 4:90
034 Wing moulded in nylon	sw. cr. 15:—	/ \$ 3:50
040 Fuel tank 4 oz. with sump	sw. cr. 26:25	/ \$ 6:20
067 Servoarm heavy duty fit Futaba S-7 (2)	sw. cr. 3:75	/ \$ 0:90
068 Override	sw. cr. 9:50	/ \$ 2:25
073 Servomounting tray fit Futaba S7 servo	sw. cr. 22:50	/ \$ 5:30
076 Servosaver kit	sw. cr. 22:50	/ \$ 5:30
3050 Exhaust manifold with clamp	sw. cr. 26:—	/ \$ 6:10
3060 Large volume silencer in aluminium	sw. cr. 49:—	/ \$11:50
3090 Heat sink black anodised for Veco	sw. cr. 30:—	/ \$ 7:—

## minicars hobby ab

P. O. Box 464, 751 06 UPPSALA SWEDEN  
Phone 018-11 20 15

# PHIL GREENO MODELS LIMITED

9 Village Way East, Rayners Lane, Harrow, Middx. Tel. 01-8667770

## R.C. CARS £ p

P.B. International	75.00
P.B. Expert Comp	56.21
P.B. Expert STD	40.23
P.B. Dual	29.18
S.G. Comp	54.25
Associated RC100	89.95
Associated RC1	59.90
Associated RC2	34.95
Mardave Formula	21.50
Mardave Saloon	21.50
Mardave Stock car	21.50
Ke'jon Stock car	29.50

PLUS A large stock of R.C. car spares always in stock including P.B. Associated, S.G., etc.

All prices correct at time of going to press but subject to alteration.

## R.C. ENGINES

Just arrived:

Super Tigre X21 ABC car	40.87
Veco 19 inc sil	24.50
HB 20 inc sil	24.50
Super Tigre 19 ABC car	36.50
K & B 21	47.50
OS 20 inc sil	19.19

ALSO Veco/McCoy conversion parts, including chrome piston/liner assembly, stoker crank-shafts, and High comp heads, etc. Send S.A.E. for price list.

## TUNE UP ACCESSORIES

SILENCERS	£ p
Semco Car	6.95
Semco Car (adapter Veco 19)	1.95
Preston Car Sil	7.95
S.G. Car Sil	7.50

TANKS	£ p
PB Quick Fill (4 oz.)	2.12
Johnson Metal Tank Kit	1.95
Johnson Chicken Hopper Comp	11.55
New GP Racing Tank (Sumped)	7.50

PB RACING HEADS	£ p
Veco/McCoy	7.50
ST 19	7.50
ST 21	7.50
PB Piston Slide Carb 3/8th in. or 7/16th in. Spigot	14.00
Perry 40 Carb.	6.95
Perry 61 Carb.	6.95
HB 20/Veco 19 Heat Sink Head	4.50
PB Heat Sink only	1.95
New GP Slide Carb for K & B 21, OPS 21, ST X21	16.50

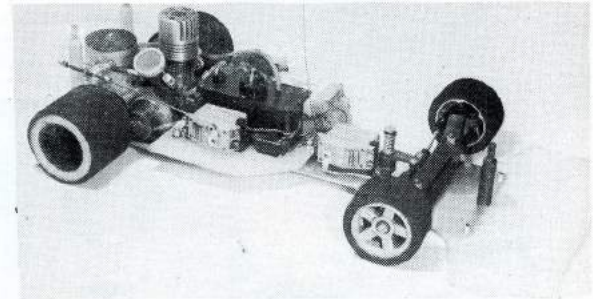

## New P.B. Expert International kit.

New P.B. International took 1st in Formula One, 1st in Sports, Lilford European Easter Meetings. Kit price £75.00

## RADIO

Futaba medium 2 FD 22m servos	63.50
Futaba medallion 2 'brick' servos	60.00
Futaba twinstick 2 FD 17m servos (dry)	83.00
Futaba steerwheel '2' FD 17m servos (dry)	83.00
Sanwa mini 2 drycell	54.95
Sanwa standard 2 drycell	79.95
MacGregor 2 drycell	52.50
Futaba FD 17m servo (waterproof)	18.50

Nicad conversion for above always in stock.

PLUS Full range of Futaba, MacGregor, Sanwa and Skyleader Radio.

ACCESS! BARCLAYCARD!  
HOBBYCARD! H.P. TERMS  
PLUS FAST MAIL ORDER.

Lectricar with proportional speed control, Porsche or Escort, £44.87.

Also large stock of BO-LINK, JOMAC, JEROBEE, ELECTRO CRAFT 1/12th ELECTRIC CAR KITS AND ACCESSORIES.

specialists  
in

## SKYLEADER FUTABA SANWA MacGREGOR

Opening hours: Mon., Tues., Thurs. 9.30-6.00 Fri., Sat. 9-7.00. Closed all day Wed.

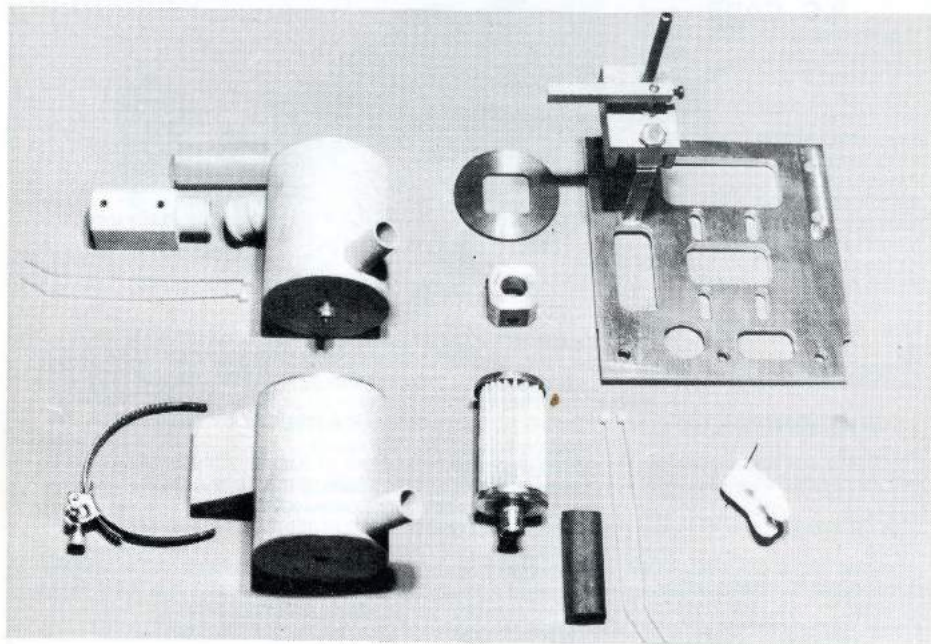

## LEXAN — PAINTING SUPER — MUFFLER

EFRA — legal  
Decals  
RC — Box (3 sizes)

AIR — FILTERS  
Right Angle Fittings  
Disc — Brake for Associated RC-100  
and more . . . . .

## MODELL — CAR — VERTRIEB

Postfach 12 D — 6842 Buerstadt/West-Germany

# STEERING GEOMETRY

## OVERSTEER AND UNDERSTEER

A CAR oversteers when it responds more freely than intended to a turn of the front wheels. What happens then is that the driving wheels at the rear instead of pushing the car forward in a straight line, as when the front wheels are not turned, continues to push forward as before, but the front wheels are no longer directly in front but to one side. This encourages the rear end to spin out and the already turned front wheel give added encouragement. The inside wheels tend to lift and may well roll the car; at the best the spin out slows, stops, or otherwise impedes the forward progress of the car.

With understeer the car wants to continue on its straight line, and resists the turning movement of the front wheels. The driving force behind is stronger than the turning force in front. The *outside* wheels would try to lift in this case, but the inside wheels also want to lift in the circumstances. If these two forces can be balanced, an ideal situation exists for the creation of a four-wheel drift round the corner. In full-size racing practice this is the common practice, with model car racing it is only just beginning to be achieved by more skilful drivers — and even more important — more skilful setting up of the car beforehand.

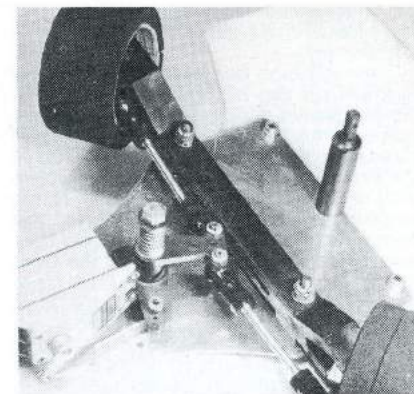

*Ingenious method of achieving Ackerman steering with smaller circle described by inner wheels as used on PB International cars (and now by some U.S. kit people).*

## WHAT ARE THE INFLUENCES?

What desirable changes can be made towards achieving the ideal condition? A number of factors are involved all of them contributing something to the solution. They are (not necessarily in order of importance):

1. Ackerman steering effect.
2. Toe-in of front wheels.
3. Caster of front wheels.
4. Camber of front wheels.
5. Tyres:
  - (a) Width.
  - (b) Hardness in relation to rear wheel tyres.
6. Chassis set-up and flexibility.

## ACKERMAN STEERING

It is obvious that in a turn the inside wheel of a pair travels a shorter distance. With a line of soldiers or dancers the inside soldier/dancer marks time whilst the outside person is very nearly running. Where steering arms are at right angles to the stub axles the slower moving inside wheel slips and is worn out more quickly whilst preventing a smooth turning action. If however they are angled inwards, so that if extended they would meet centrally at a point just in front of the rear axle, then by adjusting the location of the track rod along the converging lines of the steering arms a variable ratio of radii can be arranged for each wheel. This is the simple approach to Ackerman steering. In practice to obtain any great difference in the respective radii track rod might have to

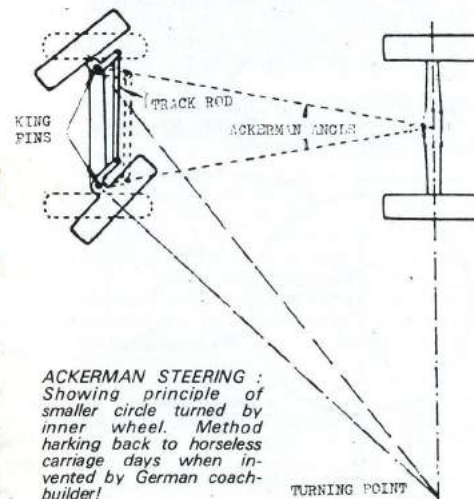

be considerably shortened and become less effective and get in the way of other components.

This limitation has been overcome, for example, in the PB system where additional links are added, achieving the same purpose but keeping the track rod line close up to the front. The earlier PB cars in the Expert Series also tackled the problem with a sweep type steering link. If the angle of the steering arm is increased this brings the meeting point of the two converging arms if extended nearer the front of the car and means that a little cross movement of track rod produces a large amount of turn. This, however, does not give the practical solution of the two wheels turning about a common point but with different though related radii. All it does is offer two unrelated radii with some of the original problems of scrub unsolved.

Indeed, it is possible to produce a position where additional toe-in is introduced to cancel too much difference in related turns!

#### TOE-IN

This leads naturally to toe-in, or setting the front wheels slightly pigeon-toed. Do not be afraid of too much toe-in. It is quite difficult to see in a model as little as  $2\frac{1}{2}$  deg of toe-in. Be bold and give up to  $5\frac{1}{7}$  deg which seems an awful lot but will improve handling and smooth response. A very easy way to make the necessary adjustment is to draw a line equal to axle length wheel to wheel. Add two lines at right angles as far apart as the insides of your two wheels. Then  $3\frac{1}{2}$  inches up these two new lines measure inwards in steps of  $1/16$ th in on each side. Join up the marks from the axle line base and you have a series of 1deg steps or

*Kingpin axis behind stub axle to provide a non-adjustable degree of positive caster.*

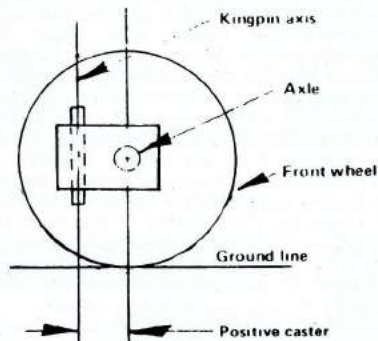

thereabouts. (The maths? Circumference of a circle is  $2 \pi R$  or  $2 \times 22/7 \times 7/2 \times 16$  which gives the answer in  $1/16$ ths of an inch as 352. There are 360deg in a circle and the difference could well be no more than the thickness of a pencil mark, or as accurately as one can reasonably draw it. No good for big angles of course but fair enough for little ones!)

In any corner the tendency is always for the inside wheel to try to lift off in an endeavour to maintain a straight line. For this reason racing "chair" motor cyclists have their passenger lean over to the lifting wheel to counteract this with weight transference. Or, to take another example, banking a curve on a race track to enable cars to go round faster, that is, without the inside (or lower on the bank) wheels lifting.

#### CASTER

Apart from toe-in there are other ways in which the wheels can be positioned in relation to the kingpins. These kingpins can be dead upright, like an old lady riding a bicycle, can be leaning backwards, or leaning forwards. A great many car kits for the sake of simplicity have the stub axle positioned behind the kingpins. This provides positive caster which is what we want. It helps to keep the wheels down by its forward rolling action, thus reducing in a small measure the lifting tendencies noted already in a turn.

This type of caster cannot be altered without making up a fresh pair of steering units. A more adjustable form has the line of the kingpins on the same axis as the stub axles, which has the disadvantage from the builder's point of view that it is rather more complicated to make. It is worth the trouble however as the degree

*Kingpin axis on line of sub axle — more adjustable but less simple to make. Perhaps worth the trouble.*

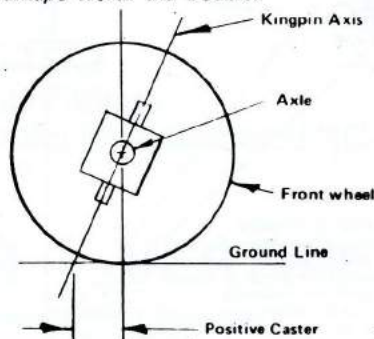

of forward tilt can be adjusted to suit a particular car setup.

With kingpins and stub axles on the same line and upright, there would of course be no caster action at all, which would be a pity but certainly not a fatal defect!

#### CAMBER

Here is yet another way the wheel can be positioned. The top can lean inwards, which is negative camber; or outwards which is positive camber. The former is the more desirable since it tends to press more of the tyre surface on to the ground, hence greater adhesion. This will be achieved in two ways. If the stub axle is bent slightly this will have the desired effect, and tyres will wear to conform to their angle on the ground surface. Better perhaps is to leave the stub axle unchanged and adjust the angle of the kingpins to be very slightly inclined inwards.

These latter two alterations, caster and camber, will not solve problems of steering in a miraculous way. In fact most drivers and manufacturers tend to ignore them, or give only slight importance to them. The painstaking constructor will take note of them.

#### TYRES

Current rules give wide latitude in the matter of tyre tread width — with 1 in. minimum up to  $2\frac{1}{2}$  in. maximum. Less generous is diameter, minimum front being  $2\frac{1}{4}$  in, rear  $2\frac{1}{2}$  in. However, this should enable some considerable variations to be achieved before even considering the other important matter of tyre hardness. Usual practice is to have quite narrow tread at the front and massive width at the back. Normal range of tyre widths seem to run between  $1\frac{1}{4}$  in. width of tread (not making use of minimum 1 in. tread!) to  $2\frac{1}{2}$  in. — the maximum. Diameters which are not controlled under BRCA rules at the top end, generally range between  $2\frac{3}{4}$  in. to  $3\frac{1}{4}$  in. A good mix would be  $2\frac{3}{4}$  in. front tyres of  $1\frac{1}{4}$  in. width and  $3\frac{1}{4}$  in. dia. rear  $2\frac{1}{2}$  in. tread.

This takes no account of tyre consistency which ranges from soft through to hard, and the actual make-up of the tyre compound. Soft tyres give more bite and have more actual tyre area on the ground to provide tractive effort, so will be found as the rear driving wheels equipment. Since understeer is better than oversteer front tyres will be harder, that is, have less bite, so that oversteer and spin out problems are avoided.

Two other factors will influence tyres to

*Camber — with wheels leaning in to provide negative angle. Tyres then wear to shape for better adhesion.*

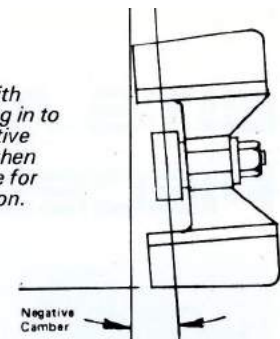

be used, namely track surface and weather conditions. Tracks vary very much in their surface, which itself will change during a week end's racing by the deposit of rubber on its surface providing more adhesion and involving a change of tyres during a meeting, perhaps within an hour or two. Wet weather again involves tyre changes so that in some countries racing is stopped for the wet — notably in parts of USA where rain is less common than in the UK! British and continental drivers have tackled the problem successfully and racing goes on whatever the weather, though times are slower and cars lose adhesion. Softer rubber is the answer, but then tracks dry out during a race and all the "fullsize" problems of "do I fit rain tyres?" arise.

Tyres remain the least developed of model car accessories. They are stamped out from rubber or synthetic sheet, wasting some 60% of their content; have to be stuck to wheel hubs in a very "un-mechanical" manner; wear out quickly; have no certainty of exact character from batch to batch. A number of substitute synthetics are being tried, there are a few moulded (but expensive) tyres in use, but so far no manufacturer has come up with a real answer, though there is a very good variety on offer both from domestic makers and from overseas. The experts swear by their own particular favourites, but there is no unanimity, nor have any of the fullsize manufacturers shown interest in producing a model racing tyre as yet.

I have dealt only very lightly with this important subject since it demands a review in depth including manufacturers' comments as well as users'.

*A further instalment follows on the subject of "tweaking" or getting the wheels standing four-square on the ground.*

*Thanks are due to RACING CIRCUITS/CHUCK HALLUM for use of their excellent sketches for caster and camber plus some of their equally excellent conclusions.*

# BITS AND PIECES

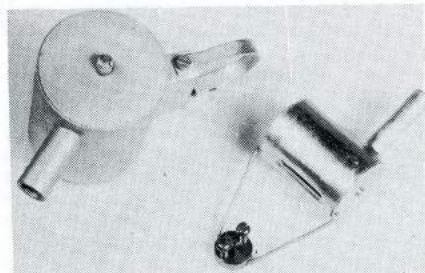

Attachable silencers: The Ted Longshaw and small Veco size by Mardave.

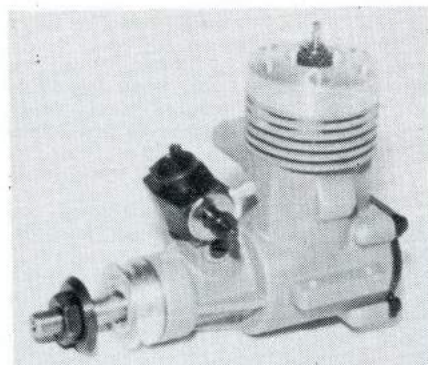

On the secret list! Prototype Irvine engine for us in 1978?

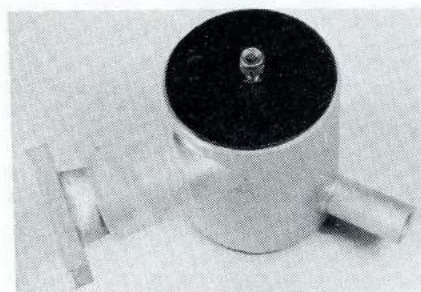

Pleated "dustbin" silencer with attachment and manifold.

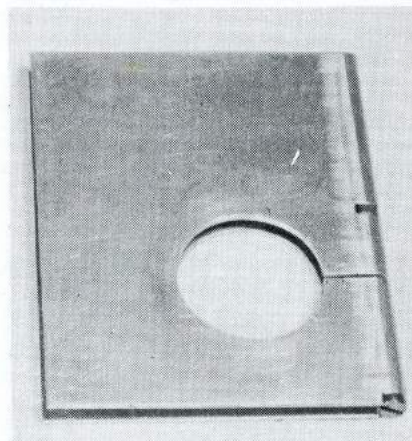

Heatsink by Mardave — the simplest possible for stock-cars.

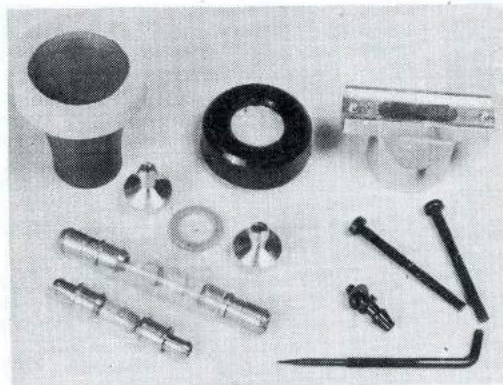

Above: Pleated carb filter : ditto Perry : then latest SG manifold for S. Tigre. In the middle: fuel line filter and in front two sizes of Sullivan filters (Crap Traps). Bottom right: SG needle and pressure tank connection. On far right: SG carb filter.

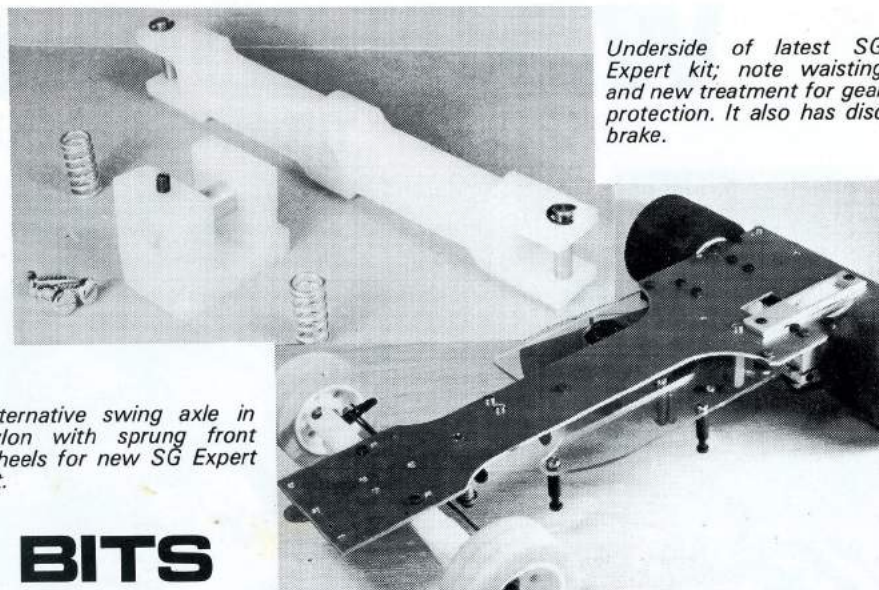
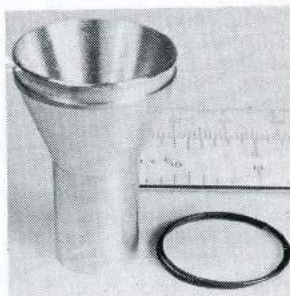

Underside of latest SG Expert kit; note waisting and new treatment for gear protection. It also has disc brake.

Alternative swing axle in nylon with sprung front wheels for new SG Expert kit.

# BITS AND PIECES

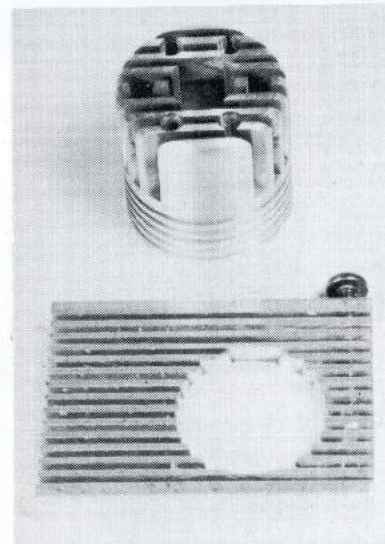

Two more heatsinks. The popular "big head" from PB Products — this one suits Veco. Below, the usual "cooking" head in sizes to fit engines in use from Mardave.

Parts here illustrated either bought by Editor (extravagant chap!) or made available through courtesy of PB Products, Mardave, World Engines Ted Longshaw and Phil Greeno Models. Manufacturers, importers, traders I will gladly look your wares over and photograph for the benefit of all concerned.

Expensive but beautifully made. The impecunious can make their own from basic parts displayed — you add the lids and work! — but much much cheaper.

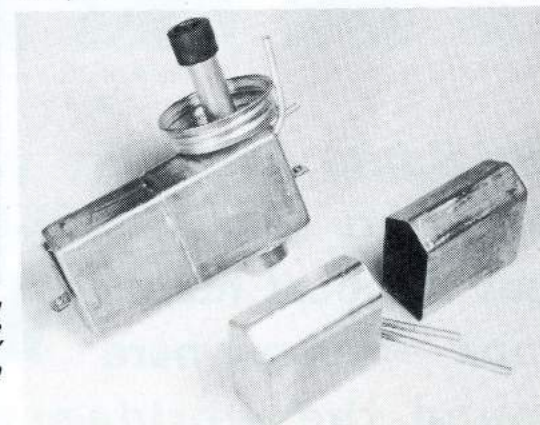

# WORLD CHAMPIONSHIP

THORP RACEWAY, USA — JULY 2, 3 & 4, 1977

**WORLD  
CHAMPION**



**BUTCH KROELLS**



**BILL JIANAS**  
*2nd Place*  
**TOP QUALIFIER**



**MIKE ROWLAND**  
*4th Place*



**RICH LEE**  
*5th Place*



**MATT AZZARA**  
*6th Place*



**CHUCK PHELPS**  
*7th Place*



**GARY BURIANI**  
*9th Place*



**ROGER CURTIS**  
*1st 'C' Main*



**GENE HUSTING**  
*3rd Place*

Associated Cars & Spares are available from the best hobby shops — everywhere around the world.

**IF YOU WANT THE VERY BEST  
BUY ASSOCIATED**

## ASSOCIATED

1928 EAST EDINGER,  
SANTA ANA, CA. 92705, USA



## EUROPEAN CHAMPIONSHIPS

WITH FRANKE, Switzerland winning the Formula event and Per Gustafsson of Sweden taking the Sports/GT some surprising changes of fortune amongst the recognised ace drivers of Europe could be expected! British entries could not quite make the final of Formula but Keith Plested and Dave Martin were third and fourth respectively in the Semifinal run-off for the last two places in the final, and were ranked seventh and eighth respectively. Line-up for the Sports/GT showed a much stronger GB representation with Keith straight through to the final in number two spot and Ted Longshaw heading the Semifinal run-off followed by Phil Booth at 3 and Phil Greeno at 6, making a show at a Euro event whilst still a "first year driver!" Ted should perhaps have gone straight into final since there was strong disagreement with the final

*Formula line up : Left to right: Sabbattini : Mares : Franke : Ruchat : Tassaux : Ron Ton.*

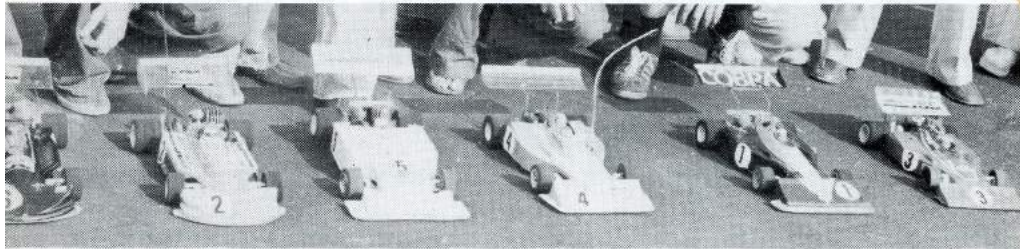

heat result which displaced him, but Ted, as President of EFRA and on the Jury ex-officio, was in a delicate situation. He made his points very strongly but equally properly conceded to the majority jury view to uphold the otherwise excellent timekeeping team.

Formula Final provided a dingdong battle with Sabbattini and Mares of Italy and Franke of Switzerland all on the same lap, until plug trouble beset the Italian and the struggle became a duet. Then Sabbattini came back into the race with little chance of catching the leaders — but what a wonderful try. Driving like a madman with his minions male and female as extra marshals he fairly howled round to achieve a thoroughly deserved third place. Ron Ton of Holland was another casualty and never really showed after an early lead then dropping out at the halfway mark, though still placing fourth. Meanwhile Franke held on to his lap lead to the end, with Mares hard on his tail.

Only Mares and Tassaux achieved double placing by making the second final for Sports/GT. Again two Swiss were there Fiocchi and Zahnd, with Keith Plested for GB and Per Gustafsson of Sweden. A great driver the young Swede was tipped to me as the likely winner by Phil Greeno — and so he proved. Run clockwise it proved a faster race as might be expected with Sports/GT by some seven laps. For 107 of them the race was very much between Keith and Per Gustafsson with Keith momentarily taking over the lead at lap 90. Alas it was not to be, the demon of fuel mixture and plugs struck and Keith was out. Per coasted on steadily to make 124 laps, five ahead of second man Fiocchi of Italy.

It is interesting to note that winner in each case came from drivers who had run off for a place. Did that extra run of fifteen minutes prove of real value in assessing adjustments for thirty minute final? Or is this just a coincidence?

The Paul Ricard Circuit lies a few miles outside Lyons near the village of Lentilly in a clearing of a wooded area with banked up spectator levels on one side, splendid drivers stand opposite with awning covered pits alongside. Behind lie more woods, with clearings for a camping village where the Italians had a noble tented entourage, with Dutch, German and French tents and caravans of more modest style. An elegant ship's type flag mast carried the national flags of the fourteen EFRA countries. Final detail was the electronic score board giving lap by lap figures for contestants, relayed from the ground floor of the drivers stand which housed the six human lap counters with their recorders. This magnificent track is a replica in miniature of the full size racing

*Heading: Quiet moment scene at Paul Ricard Circuit. Below: Glimpse of tenting in the woods behind — this is a French group.*

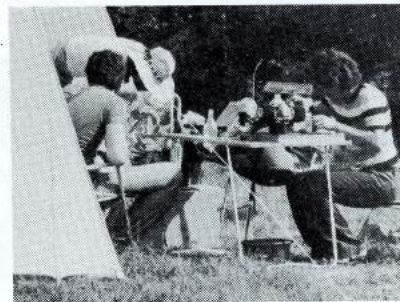

circuit of the same name, and has been achieved with the sponsorship and continuing support of the Paul Ricard company which sells that popular French tippie Arisette.

Teams began to assemble at the beginning of the week giving adequate time to learn the circuit. Everything had been laid on most efficiently with plenty of 220 volt sockets to plug in for power tools, accumulator recharging and the like (I was told that the Italians had brought a lathe though I did not actually see it!). Although finished in a tarmac surface the track was very bumpy with the faster cars apt to do wheelies along the straight and very very wearing on tyres. Panic calls to late arrivals on the British team were made for further supplies! As time wore on it was evident that harder and harder tyres were to be the order of the day.

Heat was also a problem. Temperatures were very much of a Mediterranean order, with the ladies wearing less and less each day though not achieving the topless condition which we enjoyed at the nearby swimming pool in Charbonnieres, where some of the British were staying — others at another village just by, Dardilly. The hot weather made fuel adjustment a special anxiety. With engines running just right for five minute heats they were running lean in semi finals and finals, with frequent plug change stops but this did not manifest itself until virtually too late to cure!



Courtesy of FBA News

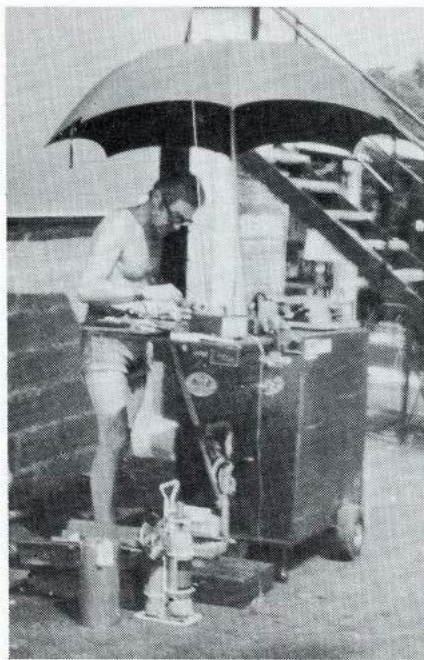

But what of the opposition? All the member countries (except Eire) put in entries which meant nearly a hundred cars to sort out with teams of seven to be slotted in. Heats were announced early, and a trial heat with fellow competitors run before the serious business began so that drivers could get an idea of who would be baulking them or not. Meanwhile the track was open for practice with considerable interest in lap times. Early 16 secs. gave way to 15, then 14 which seemed about par for the course, to break this would give rise to a buzz along the pits.

It was particularly pleasant to meet some of the entrants from countries new to the hobby but full of enthusiasm. We liked the Spanish approach who tended towards more interesting machinery, if not the fastest prototypes, such as the six-wheeled Tyrrell. Supply position was an evident problem, heat sinks, silencers and the like being home made rather after the American pattern with several small stack pipes seen a year or two ago. They also provided a couple of the simplest starter assemblies we have seen based on ex-car starter motors. One made up from a Spanish version of Dexion we shall certainly copy for simplicity and ease of construction. The other was mainly of wood and folded up when not in use. Both were ground and not table fixtures.

*Joe's Models! This Belgian entry left nothing to chance with absolutely everything on his mobile workshop.*

*Per Gustafsson Sports/GT winner holding his Minicars prototype likely to burst on the market shortly.*

*Willi Schneidinger, West Germany, never got a run but had the nicest finished car. Pity there was no Concours Award.*

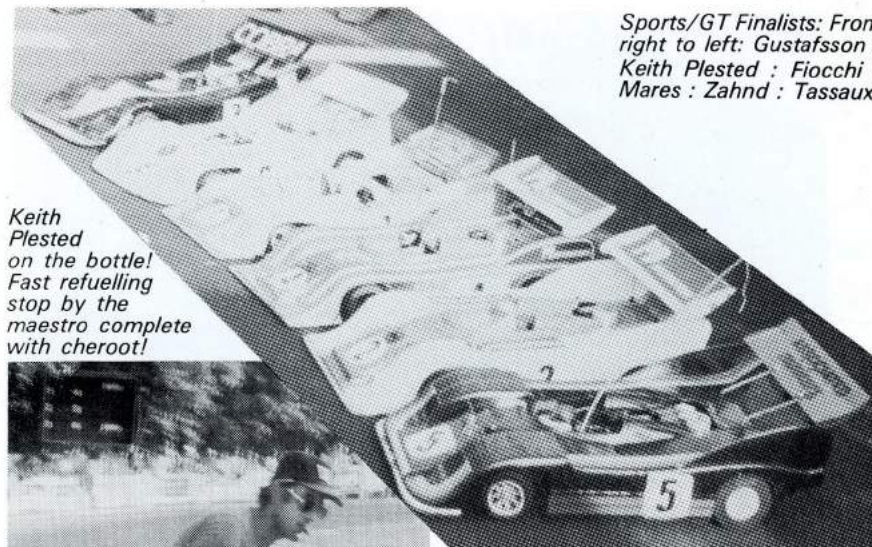
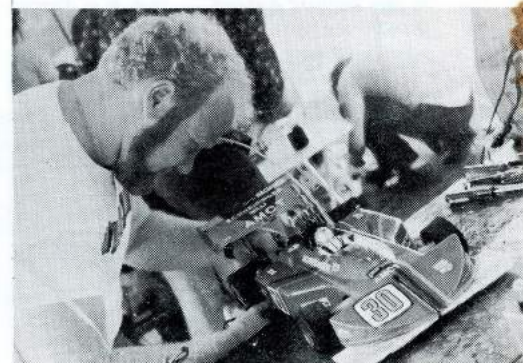

*Sports/GT Finalists: From right to left: Gustafsson : Keith Pledsted : Fiocchi : Mares : Zahnd : Tassaux.*

*Keith Pledsted on the bottle! Fast refuelling stop by the maestro complete with cheroot!*



folded paper filters used as oil filters in fullsize cars. They are about the size and shape of a cotton reel and are a Fram product. Similar filters offered in U.S. by Micro Racing. We will try to get the part number for those who would like to try them.

Scatch built cars continue to be rare. Virtually all were either pure kit or with very minor modifications, or, in some cases a mixture of two kits. PB International we were pleased to see was in good supply, with SG prominent and certainly *de rigueur* amongst the Italians! Other European products included the interesting Dutch Serpent, originally a fibreglass/alloy sandwich but now with conventional all alloy and the promise of a new Challenger design from Minicars of Sweden in the autumn. With Per Gustafsson a Euro champion it should be popular though not intended to be hot racing material.

American kits as well as American design influence very much to the fore. After winning at Pomona Associated again made a terrific showing at Lyons (we can hardly wait to put ours together!) — rather naturally their top car the RC 100. One or two Deltas were seen, and some Marker parts, but basically Associated.

The Swiss Brem cars were the most technically interesting. They are the only production kit (except Thorp in US) still using a belt driven racing layout. This is particularly curious since the chassis is not

Indeed, variety of starting arrangements provided most of the novelties and will be subject of a special feature. In the car and mechanical line progress was very much along stereotyped lines. The mixture as before but just that little bit better. World Champs visitors had seized upon a very useful US filler cap for pressure tanks which allowed a large spouted filler to be inserted; did not leak and had a large spring loaded cap which lifted up and down like a kettle lid when pressure got too much. Keith Pledsted lost his ready made and had to knock up his own replica. Perhaps he will market a British version.

The other novelty — or fad even? — very noticeable was the use of paper filters for carbs. These are the typical concertina

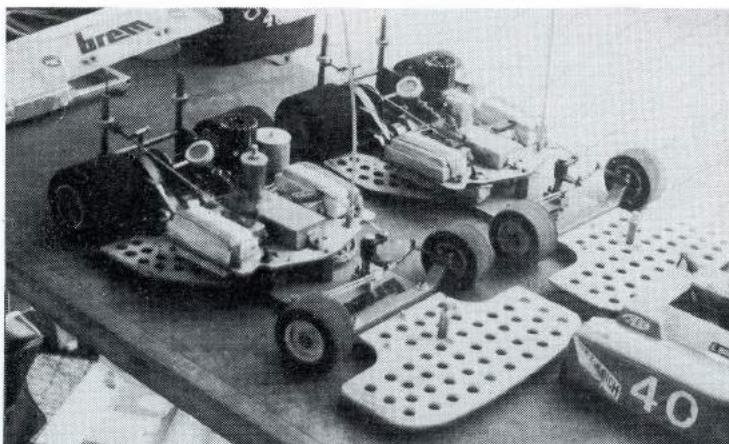

*Brem cars in the pits. Note belt drive, disc brakes, and much boring of holes.*

sprung (like a stock car model for instance) so that toothed belt drive would appear to be unnecessary. However, they are so beautifully prepared that one such car made the semi final!

Brem should certainly be given full credit as the first production car to provide disc brakes! Their version is further in-board than the PB variety and is lavishly pierced with holes. This same hole piercing fondness will be noted on the whole of their chassis — reminiscent of a well-known Swiss cheese! I do not know actual amount of weight so saved, and whether it is worth the effort of all that drilling.

Minor variations on the theme included a Delta with light clear plastic shielding all round to keep to radio clean on the shaker plate. This had to be re-stuck down every time the body was put on — sticking in part direct to it — so that it was something of a laborious task. Another little gimmick was fixing the wing mount on one side through the silencer dustbins. Some petrol

Chest harness favoured by some — notably German drivers. This holds a Simprop Alpha Tx.

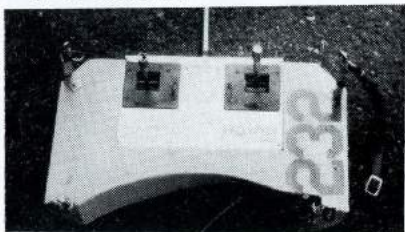

tanks seen outslung behind the rear axle line to bring weight back.

General bumpiness of the straight was such that some people were bringing weight forward. Phil Booth found it necessary to add over two ounces of dead weight to the front body fixing mount to reduce wheelies engendered by the ramp-like bumps. With his great belief in a flexible front end this must have produced special problems for Franco Sabattini. He evidently cured them for when he was going he was tremendously fast.

All in all it was a splendid meeting. I shudder to think what it would have been like in bad weather! August is the French holiday month, and half the places were shut, both restaurants, shops and hotels, and August 15th is a public holiday as well through most of Europe. Eating out was probably the great social problem, though the organisers did give a dinner but in somewhat haphazard fashion with some disgruntled would-be diners walking out . . . less said the better. Commemorative plaques by the way, beautiful and set a very high standard for future events.

#### Results:

##### F1 Grand Prix Cars : Final

1. Franke, Switzerland, Associated, K & B, 117.
2. Mares, Italy, SG, ST X21, 116.
3. Sabattini, Italy, SG, ST X21.
4. Ton, Holland, SG, ST X21.
5. Ruchat, Switzerland, Scratch + Ass. gears, K & B.
6. Tassaux, Belgium, Cobra (a mod of Associated), K & B.

##### Semi Final (1 and 2 into final)

1. Sabattini.
2. Franke.

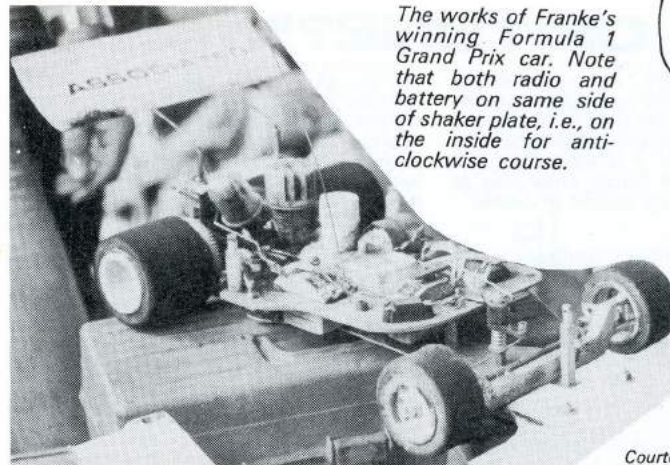

*The works of Franke's winning Formula 1 Grand Prix car. Note that both radio and battery on same side of shaker plate, i.e., on the inside for anti-clockwise course.*



*Courtesy of FBA News*

3. Keith Plested, GB, PB International K & B.
4. Martin, GB, PB International, K & B.
5. Meyer, Holland.
6. Zahnd, Switzerland, Associated.

##### Sports/GT : Final

1. Per Gustafsson, Sweden, Associated (with Challenger wheels?), K & B, 124.
2. Flocchi, Italy, PB International, K & B, 119.
3. Zahnd, Switzerland, Associated, K & B, 114.
4. Mares, Italy, SG, ST X21, 113.

*Light relief! "I can beat the lot of you on my skateboard!" Who was the late comer?*



5. Keith Plested, GB, PB International K & B, 107.
6. Tassaux, Belgium, Associated, K & B (with PB carb), 78.

##### Semi Final (1 and 2 into final)

1. Gustafsson, Sweden.
2. Zahnd, Switzerland.
3. Phil Booth, GB, PB International, K & B.
4. Lemaitre, France.
5. Ted Longshaw, GB, PB International, K & B.
6. Phil Greeno, GB, PB International, K & B.



## "OUT OF TUNE?"...

*There are always two schools of thought in engineering — model engineering in particular! — the purist "right" way of the professional engineer and the rule-of-thumb "it's right if it works" of the practical man at the bench. How nice to have the protagonists locked in battle!*

Dear Sir,

I feel I have to write to complain about certain points in Fred Livesey's engine tuning article in Issue No. 1.

Firstly, as Mr. Livesey suggests, his figure of 40,000 rpm on load does cause controversy, certainly with me. Has he any evidence that his engines actually reach this figure under load? American R & A rods for K & B engines are "only" rated at 35,000 rpm, these probably being the best available, and the conrod is the weakest part of the engine at these speeds.

Secondly, still on the subject of conrods, how on earth does he expect anyone to make an alignment testing rig having an adequate degree of accuracy with the tools he lists at the beginning of his article.

Thirdly, on the subject of accuracy, his method for skirt relieving on the piston absolutely horrifies me. I have serious

doubts as to whether this is indeed necessary or desirable. However, should anyone decide to do this mod., what degree of concentricity can one expect between drill chuck axis and piston axis, with a piece of carved dowel in the piston? If one could get centres concentric within 0.010 in. I would be surprised, and how could you guarantee not to get a tapered piston? All sorts of horrible side effects spring to mind.

Now we come to Mr. Livesey's master stroke. I hope no-one has actually tried to reduce end float in their crankshaft by grinding material from the face indicated in Mr. Livesey's sketch. He has, in fact, got it the wrong way round and you shim this area to reduce float.

Fifthly, at the bottom of page 35 he suggests that a complete cycle takes place ever two revolutions of the crankshaft. Now I understand Mr. Livesey races 4-stroke engines!

I could go on, challenging his statements about porting, cylinder head temperatures, nitro content and thermal efficiency, but this letter is getting rather long...

In conclusion I must say that the general principle of this type of article is excellent, but this particular article should have been checked for content by someone experienced in glowplug engine tuning... If you can stop this sort of thing happening then you will be assured of at least one more regular reader.

Yours faithfully,

Richard J. Hamilton

### FRED LIVESEY'S STERN REJOINER

Dear Editor,

In reply to Mr. Hamilton's letter I say that my first reaction was one of rage! (or slightly upset). The thoughts passing through my mind of how would he (Mr. H.) like to give up two days of his annual holiday to write an article or how about an article from him to enlighten us "all"?

As for his comments, first I observed in an article by another contributor (page 28) figures of 70 mph quoted. Using a gear ratio of 5.3 to 1 with 3 in. diameter wheels gives 67 mph, approx. 40,000 rpm. His comments about special rods for K. & B's leave me the only reply that full chat down a bumpy straight the engines must revolve far above 50,000, never mind the 40,000... food for thought I think.

The accuracy of testing jigs he mentions leads me to say most model car enthusiasts will have to be able to use and possess squares, files, etc. if they are to be successful in competition. The jigs are simple exercises for the skilled model maker. I work with trainees who can learn the use of squares and file within a day so where's the problem?

The third adverse comment I answer by the statement that if Mr. H. is ever in the position to watch a honing machine in operation he will find if he studies the mandrel revolving it rarely runs true. The reason the operator can achieve accuracies in the order of ten thousandth of an inch, or even less, is the fact that the liner is hand held and follows the error. This is the same principle for achieving accuracy in piston relieving. A well-known competitor who has had much success this year, i.e. probably won the most open meetings this year, uses a similar relieving principle on his pistons. He laps the piston for his K. & B. upside down in the cylinder liner initially, and as Mr. Hamilton well knows the K. & B. liner is tapered. This gives a taper to the piston, i.e. smaller in diameter at the bottom of the piston. The only side effect as I can see

is that makes the engines winners! If Mr. H. does not believe me the only thing I can say is talk to someone who was at Hull on September 25th — the winner of the GT final certainly flew probably at 40,000 rpm.

The end float comment is quickly answered. In the process of transferring my drawing to the mag the shim appears to have grown slightly, i.e.

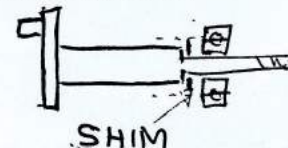

Shim same diameter is inner ring of ballrace.

Shim used in this position only because it is clamped between crankshaft and inner race of bearing. The crankshaft relieving is quite easy. Place the crankshaft in an electric drill, placed on a bench stand. By using a carborundum slipstone it can be

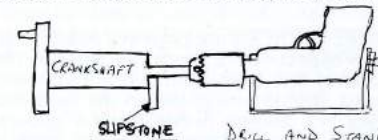

easily relieved on the bearing face. Use goggles for safety to avoid grit reaching the eyes. Shim must never be used on the outer face of the race as they are free and will revolve in the casing, then disintegrate with dire results.

As to the last comment I must hold up my hand and let Mr. Hamilton smack it. The last paragraph should have read: "Wow! Plenty of areas for improvement when you think that each complete cycle or two strokes of the piston takes only three thousandths of a second at 40,000 rpm." I do hope Mr. Hamilton will forgive me.

Sincerely,  
F. J. Livesey

IN NEXT ISSUE (Out end of December) :  
LOOKING AT THREE GREAT KITS : PB  
INTERNATIONAL : SG : ASSOCIATED  
RC100 : "TWEAKING" OR GETTING THE  
CHASSIS SQUARE : "WORLD CHAMPIONSHIP"  
STOCK CAR MEETING : CLUB  
& TRACK REPORT : EFRA NEWS :  
TECHNICAL THOUGHTS ON POMONA &  
LYONS : THE NEW ELECTRICS : ONE-  
TWELFTH SCALE POWER IS COMING :  
BITS & PIECES.

## MICK CHARLES MODELS

New Larger Premises at  
**180 LONDON ROAD KINGSTON-UPON-THAMES**

For Everyone! — for all your modelling needs

**RADIO CONTROL EQUIPMENT, ENGINES, KITS AND ACCESSORIES — EVERYTHING YOU NEED TO COMMENCE AND COMPLETE YOUR MODEL!**

*I aim to supply you in the most advantageous manner possible — can you find any other model shop which offers the following services...?*

- ★ **C.O.D. ON ORDERS UP TO £50.**
- ★ **BARCLAYCARD AND ACCESS CARD SPECIAL SERVICE** — phone in your Barclaycard number and the goods you require can be sent to you at once.
- ★ **ACCESS AND PAYBONDS** accepted for any deal.
- ★ **H.P. ARRANGED ON THE SPOT** for all goods £20 or over in value — if your credit is good you can walk out with the goods in five minutes! Mail order customers can write or phone for H.P. forms to complete and send with their order, the goods will be sent back the same day.

**SPECIAL! 10% DEPOSIT ON H.P.**

OPENING TIMES — **Mon., Tues., Thurs. 9.30—6.30: Wed., 9.30—1: Fri., 9.30—9: Sat., 9.30—7.30.**

**Tel: 01-546-4488**

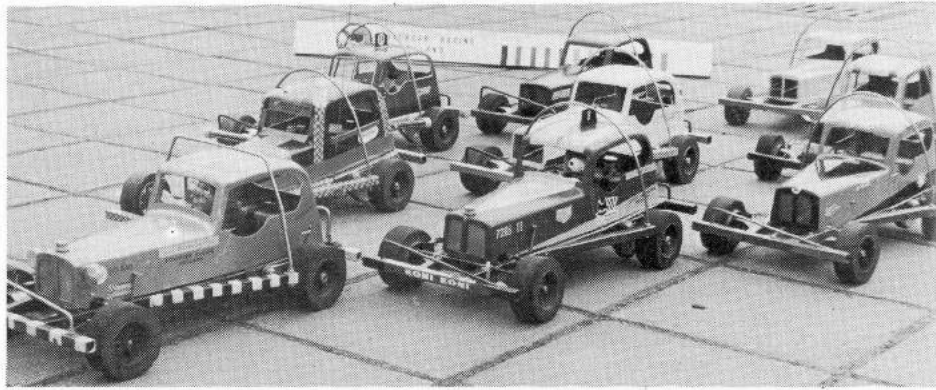

## ASSEMBLING & RUNNING A STOCKCAR

THREE CHOICES are normally available to the prospective r/c stock car racer in the shape of kits from Mardave, Ke'Jon and Purma. Mardave was first in the field and offers the lowest priced kit; for several pounds more Ke'Jon provide a slightly more finished chassis frame — nerf bars being already fitted — and a working drawing in lieu of building instructions. This may be less comprehensible to the beginner than words and pictures! Finally for the racer eager to get into the driving seat right away Purma offer their kit ready assembled with only the radio to install plus engine etc., for very little above kit price. This is the answer to those who just want to race and never mind how the gear goes together. The final solution will probably be to run what the local club you are joining favours. In any event if you have the club already to join you will find opportunities of buying a used car from a member, or even find a fanatic builder who will put it together for you.

This is NOT the recommended thing! The mere assembling of the car in itself helps the beginner to understand what it is all about. Besides which making things is fun! Unless a hobby provides just that there seems no other reason to take it up. In our case we are making up a Mardave, with occasional interjections where Ke'Jon may differ in detail.

Mardave chassis comes unpainted and can be inspected for excellence or otherwise of spot welded joints. First task is to give it a good clean with Gunk or similar

*A fine degree of individual treatment is evident in this line up of the Stockcar Racing Club of Holland.*

de-greasing fluids since it will normally have an oily film to prevent rust whilst in stock. Then go over it carefully with a fine file and emery paper to smooth the toughness of welds. Do not be too vigorous in removing metal, particularly round the engine mounting plates, but be sure not to leave any sharp edges or roughage that can cause cuts and scratches later.

Two lengths of strip metal are included to make up nerf bars on each side. These are secured with nuts and bolts, including two long bolts which must be bent slightly to act as stand off supports on each side. File sharp bits off these parts, too, before bolting them on. Front and rear nerf bars are in the form of steel rods, threaded at each end. These must be bent to shape. Those for the rear in a convenient "handle" shape to form a shallow "U". Front bar is higher one side than the other, coming down in a sharpish slope, again threaded.

Front and rear bumper bars which form parts of the chassis are not drilled to take these overriders so that it is simpler to bend them first and drill to take them than to drill and have to bend to fit! Even so they will require a bit of manoeuvring to get into the holes. Nuts are included and one should be run up each threaded portion as far as it will go to locate the bars on the bumpers, leaving enough

protruding through the bottom to take the retaining nut in each case. Suggestion is made in the building instructions that they may be screwed in place or soldered. Soldering alone may make a messy joint, if you decide to do it this way, use Baker's Fluid rather than a paste flux as it helps the run better with steel. Wash off vigorously after use.

Since these bars are not intended to be removed for any reason during the life of the car a little Loctite on each screw before running up the nut is a good thing. Then file off flush with top of nut and there is another neat non-scratch job.

Steering wishbones, kingpins and steering pivot arms follow very much the same pattern as for racing car assemblies already described and can be duly mounted on chassis. Ke'Jon assembly varies slightly from Mardave and drawing should be studied very carefully as wishbones come under chassis. Remember to use file and emery paper on parts before assembly to smooth out any roughness.

At this stage the chassis can be placed on a sheet of newspaper, propped up on wood blocks and given an undercoat of paint. Ideally, red oxide or similar base paint for metal should be used. I tend to use up odd quantities of any old aerosol paint that I have by me and use intended paint for second and third coats. Do not get paint on stub axles. These will probably have a touch of rust on them and should be polished up with old emery paper, a little Rustovent if available, and a touch of oil with retaining nuts screwed on temporarily with their washers, to be sure everything is to hand.

Now comes the part where stock cars differ materially from out-and-out formula and GT kits. Driving wheels at the rear are

*Front steering wishbones on Ke'Jon stock car are located one above and one under chassis frame.*

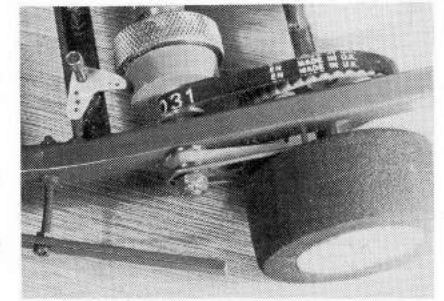
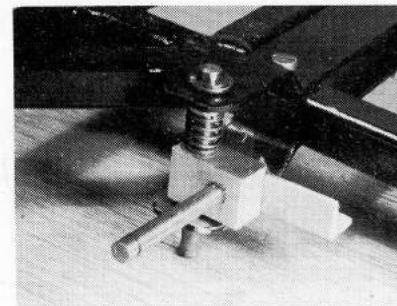

*Rear springing, belt drive, bellcrank location and side nerf bar clearly shown in this posed picture.*

fully sprung. Mardave have two plastic mouldings together with what look like outside clothes peg springs. The rear axle goes through one hole and the other hole serves for a bolt to secure to the chassis. On the inside of the chassis frame the large toothed driving wheel is located. Do not be in a hurry to complete this assembly if it is new to you. Take time to examine it thoroughly, like a wire puzzle, and get the hang of how it is going to work.

At the same time the engine to be used should be tried for size on the mounting plates which must be fitted to the engine retaining block. You will probably be using a Veco 19 so that fitting and drilling of engine bolting down holes presents no special problems. Bolt engine in place loosely. Put toothed belt over the big driving gear so that its ultimate location on gear which forms part of the clutch bellhousing can be assessed. Remove engine now and install flywheel clutch and clutch bellhousing. You will already have noted

*Mardave wishbones are both under frame with track rod above it. Both makes of car have sprung front wheels.*

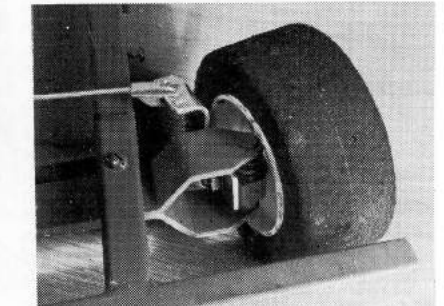

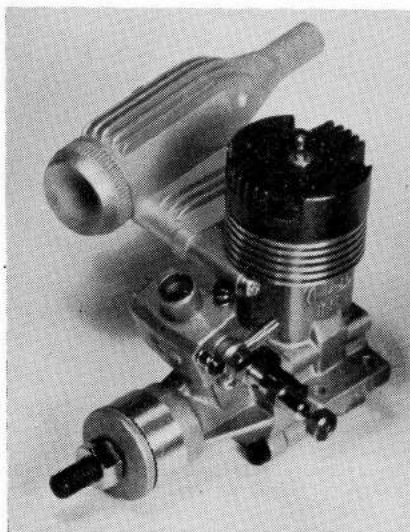

*Newcomer to engine range. Competitively priced Fuji with Schnuerle porting and silencer (whether to quietness limit I do not know!).*

that there is not likely to be a great deal of clearance, in fact the chassis frame member on that side plays quite a part in keeping the belt in place. Fitting these parts has been dealt with already for racing cars and there is no difference here. In view of the very limited clearance available be sure that parts are well bedded down and screwed up good and tight. I wondered at first if it was going to fit in, but alarm unnecessary it does!

Fitting of wheels and tyres is next operation — though most people will have put them roughly together just to see how it is going to look. As you will know both wheels and tyres have to be coated with an impact adhesive of which either Evostik or its Dunlop equivalent can be used. I like the latter since it is slightly slower in setting, but this is a personal preference, and the latest Evostik packing does claim increased adjusting time.

Do the wheels one at a time, spread adhesive on one hub then on inside of one tyre and slide it on. It is a messy job at the best of times, but can be eased a bit if you retain one of the plastic envelopes in which parts for the car come and use it as a glove for the hand slipping on the tyre. It helps too, if you rig up a threaded bolt of similar diameter in a drill which you can hold in a vice — ordinary hand-drill —

#### WHAT YOU NEED FOR STOCK CAR RACING

- 1 A Club to Join (or start).
- 2 A Track to use — make friends with local schools, car park people (big factories, stores) — a few DIY members can make up the oval circuit boards.
- 3 A stock car kit — your local dealer will let you see Mardave kit (which complies with RSCA construction rules) or Ke'Jon (which requires slight mod. to comply).
- 4 Two-channel radio Tx and Rx (Futaba, Sanwa, MacGregor, you name it).
- 5 Engine (Veco, Fuji or (hush) perhaps the Irvine).
- 6 Engine starter (Sullivan, Kavan or make your own).
- 7 Accumulator 12 volt (Varley, or ex-car, motorcycle, or any to come).
- 8 Smaller 1 1/2/2v accu. for glow-plugs (or tap off accu.).
- 9 Fuel (not too hot — good "cooking" quality).
- 10 Operating licence (£2.40 for five years).
- 11 Loads of enthusiasm and a sense of humour!

then you can turn it round as you're fitting the tyre and get it nicely and evenly on. There is bound to be some surplus adhesive on you and on the tyre. This can most easily be removed with a rag dipped in petrol. There are so called solvents on the market but nothing really beats petrol. This is a tip from Wes Raynor of Mardave who has probably put on as many tyres as anybody. With some skins petrol tends to dry and crack them, so if you're one of them, rub some lanolin cream in afterwards. It does not smell of any scent and can be obtained cheaply from Boots!

Whilst the hand-drill is in use it is a good scheme to touch the edges of each tyre on a sheet of glass paper to take off the sharp corner, rounding them very slightly. Later you may wish to have several sets of wheels and tyres to suit track and weather conditions in varying degrees of hardness. But at the start this is not really needed, though a couple of spares would be a sensible item for the tool/spares box.

It will be noted that rear wheels bolt up with the main part of the axle of larger diameter, and are fixed with a nut. This gives a certain amount of play since there is no flat on which an allen screw can bed down, only the pressure of the nut against the wheel which in turn presses against the shoulder on the axle.

Front wheels should be fitted with minimum play. A tip is to insert a paper washer between wheel and holding nut, and then pull it off when secure, thus leaving just enough free movement. Be sure to adjust toe-in with at least 5deg. on each wheel. A rough and ready angle adjustment is to draw a line at right angles to the axle line 3 1/2 inches long; at the 3 1/2 inch point measure in by 1/16 in. at a time, which amount is approximately one degree per 1/16 in. There is a little error but no more than you will get in any measurement of this sort. All the things we say about wheels in another article are equally applicable to stock cars.

The track rod joining the front wheels will be the adjuster for toe-in. Mardave recommend that a V-shaped kink be bent into it to allow minor adjustment when it is in place and also to absorb any violent side swipes. One end of track rod can be bent up at right angles slipped into one of the holes ready drilled in the pivot arms — the two outside holes (i.e., nearest the rear) should be used to take this track rod. I like to solder a washer on this bent up end leaving the other end with a threaded Kwik-link on it for fine adjustment. Most users will, I expect, prefer to leave the rod straight and have a Kwik link on each end as they require no soldering and fit in a jiffy. Those in the kit are plastic, others on the market are partly of metal, it is all a matter of favourite bits and pieces . . . no one sort can be offered as the best.

Steering bellcrank/servo saver can be connected up now to the steering assembly. Shortest simplest possible

bending up is recommended. Location in the holes provided on the bellcrank will adjust the amount of turn given to the steering. Do not necessarily take the most possible, it makes the car trickier to drive and only enough to go round is really needed. If you are building Mardave your servo will be right up by the steering and offer no problems. Throttle servo will be located in the hollow of the L-shaped radio box provided, and again connection to the engine bellcrank is of the simplest and shortest.

Plastic tank can next be fitted. A very simple rubber harness holds it in place. It should be possible to get some of those wide rubber bands that postmen use to hold letters together, failing this a good stationer will order a box (1/4 lb. weight seems smallest) which should very nearly provide enough for a club! Connection from tank to engine is via neoprene tube. Check that size provided is what you want — there are at least two different sizes. It should be cut in middle and a fuel filter inserted. Type should be easily unscrewed and taken apart for regular cleaning out of muck. Just as undesirable if not more so is track dirt, burnt rubber and the like getting into the engine through the carburettor opening so that a filter is needed here. A wide variety of types are available from simple plastic foam, which acts better with a little oil soaking, to quite elaborate

*Spring loaded self-centring steering on Stew Busby stocker. Deep U steering over-ride link can just be seen.*

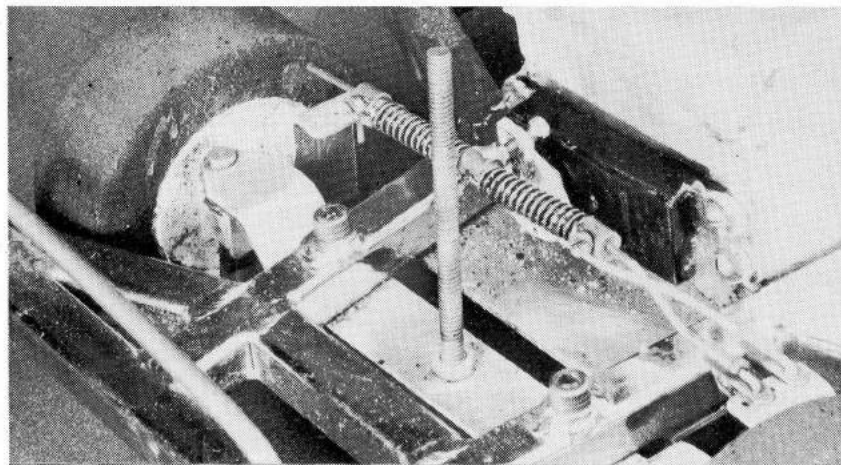

honeycomb devices. Or there is the simpler method of a piece of silk stretched over the opening and held down with a light piano wire ring as a circlip. But do filter, otherwise life of engine may be much shorter than you had hoped.

If engine is new, now is a good time to give it a tankful of fuel, running it as rich as you can at tickover speed. Ten to fifteen minutes, or a good tankful should take care of running in. Chassis can be cleaned down, radio box fitted in place and radio and battery installed. Too much reliance should not be placed on "servo tape" which holds down parts being sticky on both surfaces. It is better to wrap receiver and battery in foam sheet, rubber band them, and wedge in radio box with further foam offcuts. Servos can best be fixed with the attachments usually provided. They are quite robust physically and well protected from knocks by the stout chassis and sheet support on which radio box rests. Aerial is taped to underside of radio box, or holes can be drilled in box lid to provide an even lacing of the aerial wire. This should be adequate for reception, but there is nothing to stop you fitting up a flexible tube or "snake" to stick up out of the car carrying the aerial wire. Whatever you do, maintain the length as supplied. Should you use a stiff wire aerial (with an eye protecting loop at the end, please!) make sure length of this wire plus what is left of original aerial equals length first provided. Be sure to insulate bare wire from chassis.

You will no doubt have already fitted your heat sink. This may well be the very neat and simple type provided by Mar-

dave. You will probably wish to trim it slightly so that body fits over comfortably. Smaller thicker types should go in unmodified. Body is a good stout moulding and requires only window openings to be cut and fixing clips to be added before painting. Cut outs can be done with a handrill to start a hole and then go round the opening with a fretsaw, or can be removed with a hot soldering iron. Try this method out first on a bit of scrap plastic to see how fast your iron softens and goes through the material, and generally get a little practice in. Windscreen, rear and side window shapes are a matter of personal choice. However, if you provide good window shapes at the side a great deal of adjustment can be done without removing body, and tank can be filled via rear window. This can be achieved without any loss of realism or weakening of the body.

Rules require that beginners paint hoods white down to the waistline, changing colours progressively as you go up the skill scale. Only other rule requirement is that your name should appear on side. There is however no reason why body should not be made interesting. It will have a hard life so that full customising except for a special "show piece" body is not recommended. Any number of colourful decals can be obtained — SG do a very good sheet — and bright finishes, zig-zag patterns and so on have the very useful purpose of making your car stand out well during a race and avoid that grim business of finding you have been apparently driving someone else's car! You might even find some local tradesman who would sponsor you in a minor way for



*Elegant finish on a French car — more for show than use perhaps! Enthusiasts do spend a lot of time customising.*

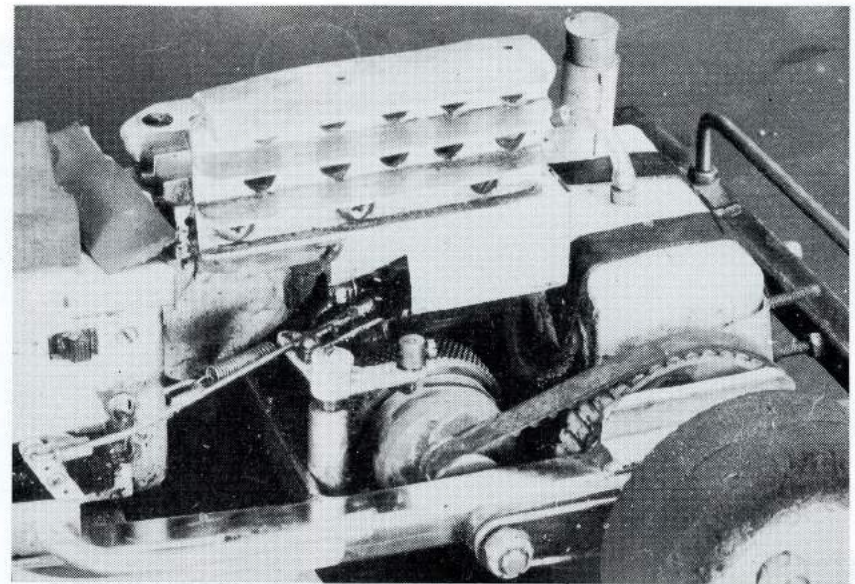

carrying his name on your car . . .

Outside Roll bars are not allowed in the RSCA rules though permitted in Holland.

There is no structural reason for this, just that the careful Dutch do not want to risk scratching some of their elegant paint jobs!

Final comments: Do not be tempted to use really hot fuel for stock car racing. It wears out engines more quickly with not worthwhile results and costs more. Use a good old "cooking" variety of about 10% nitro. Many newcomers will already have had experience of glowplug running from model aircraft use and need only remember that running on the dirty ground introduces special problems that

*Other end of Stew's car. Note fancy heat sink; treatment of bellcrank to leave one end with little "blipping" handle; additional guard to keep belt in place.*

the clean upper air does not. Clean down car and chassis after racing as thoroughly as you can. Do not leave fuel in tank or engine. Trickle charge starter battery every few weeks even if you have not been using it much; the same goes for radio batteries and glowplug accumulator.

*These building notes are offered as supplementary to "official" instructions and as useful source material to those still in a state of "armchair" modelling prior to making a practical start.*

## THE THINGS THEY SAY...

### ON WORLD CHAMPIONSHIPS

"THE METHANOL used in California is a little different from that used in Europe, as it left little whitish drops on drying and several drivers with whom we talked claimed that it increased their usual revs. I was equally surprised to discover that the Americans generally use the KB fuel with 20% nitromethane, and that others, such as Husting, run with less than 10% ADEPTE, France.

"But much time spent on getting any twist out of the chassis, bringing down the c.g. as far as possible, balancing front and rear of the car, such as Butch Kroells devoting two hours to balancing his wheels. This shows how much importance Americans attach to items that we think of as details, but it is thanks to this that their cars obtained a remarkable stability on bends." ADEPTE, France.

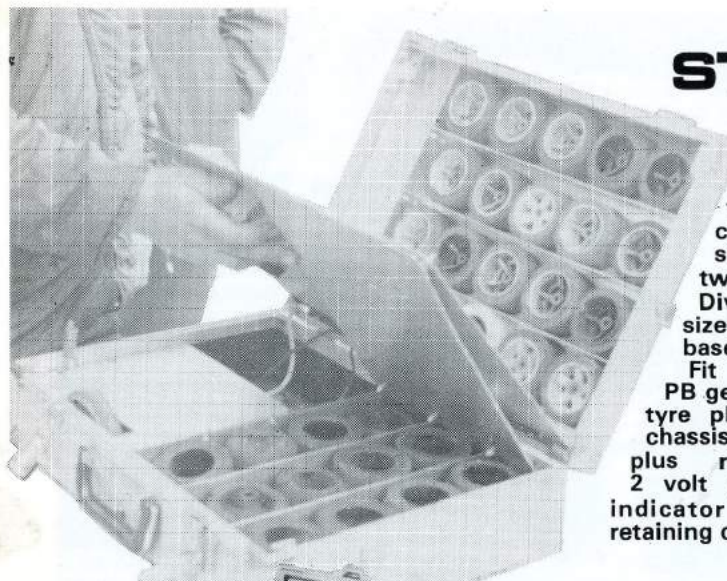

# STARTERS GALORE!

**RECIPE:** Take one photographers aluminium camera case. Throw away the foam contents. Add two sheets dural alloy and two long piano hinges. Divide up to suit tyre sizes both in lid and base.

Fit Bullet 30 to drive PB gears 4.33:1 and fit hard tyre plus locating bolt for chassis. Add glowplug rack plus rheostat controlled 2 volt glow-plug lead with indicator dial. Fit suitable retaining clips for inner lids, etc.

## KEITH PLESTED'S WONDERFUL STARTER BOX

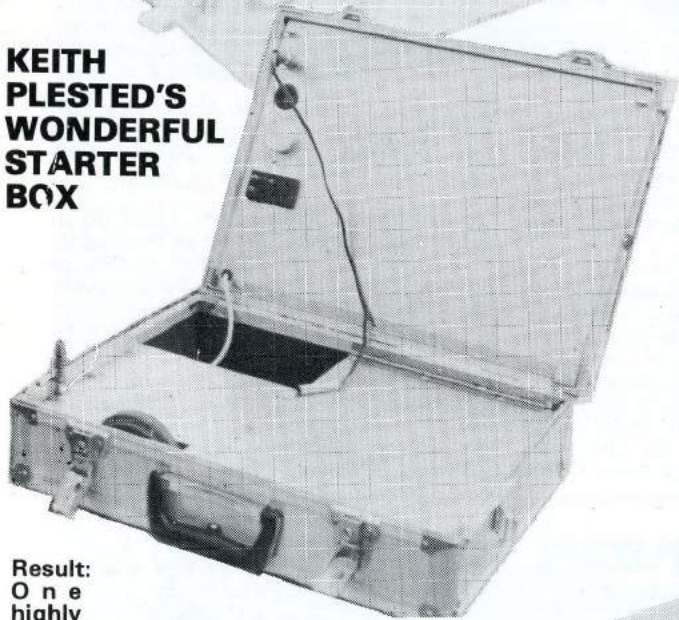

**Result:** One highly efficient portable tyre store, starter, glow-plug lead to carry aboard plane for California. Total all up weight 17 lbs. (Heavy 12 volt battery of course must be acquired at destination). Equipment will go under seat of aircraft and (after a bit of practice) provides familiar equipment in nerve testing times.

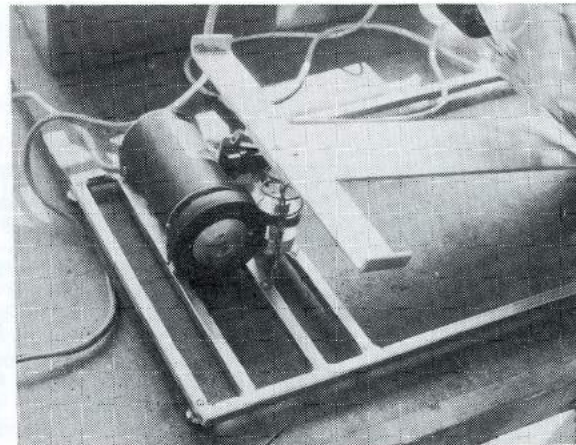
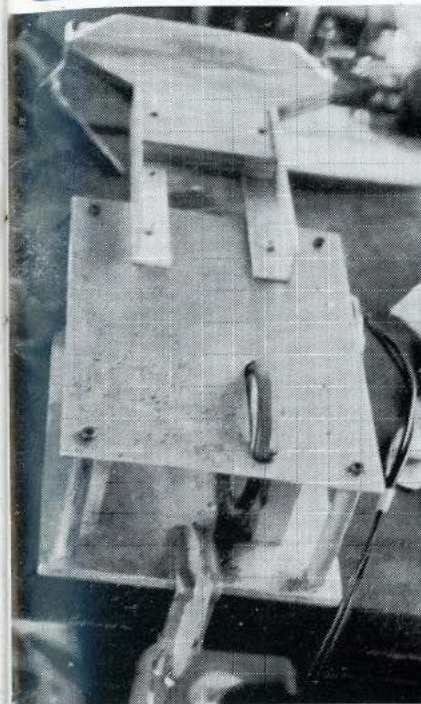

*Above: Very neat Brem starter in light alloy. Left: German take-to-pieces effort clamped to table.*

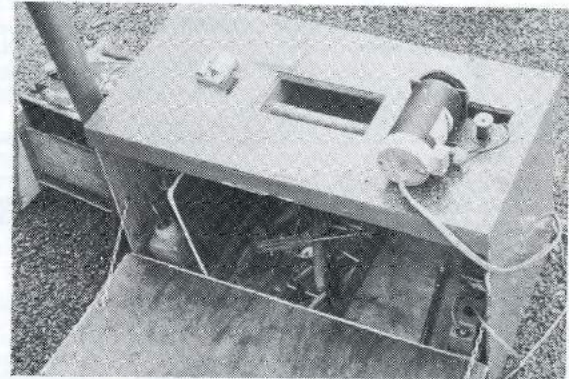

*Right: Sullivan based seen at Sandown Park. Below: Original Plested all-in-one design. Bottom right: Simplest of all from Spain.*

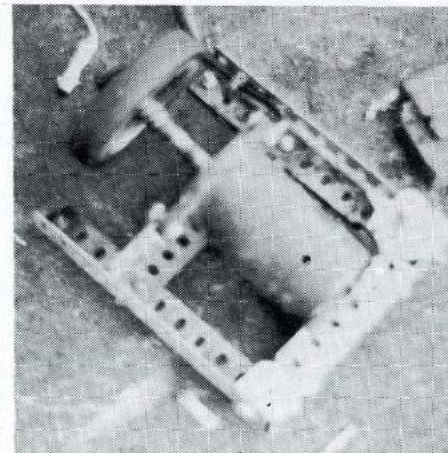
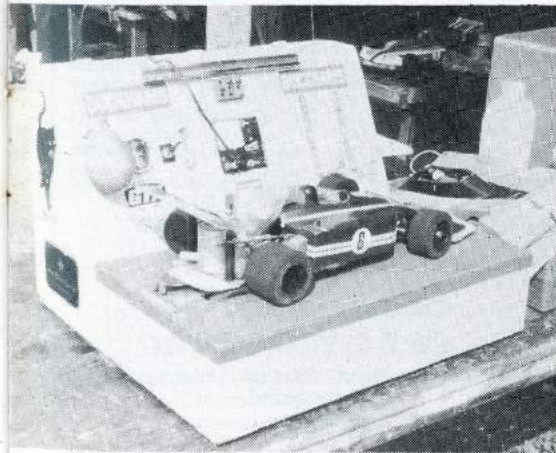



# MODEL CRAFT

5 CROSS STREET, BLABY, LEICESTER.

Telephone Leicester 771397

## ALL MARDAVE SPARES AND KITS STOCKED

FREE POSTAGE ON KITS: PARTS 50p: DECALS 10p

For **SUPER TIGRE** performance at **VECO** type prices try the astounding **NEW FUJI 198B** Schnuerle ported only **£25.95** p&P 50p. We have had only good reports so far on these motors. Don't be put off by the low price, this is a combination of Quality and Performance. **DIE CAST FINNED** heatsinks (Also suits Veco & H.B.) **£4.25** p&P 25p.

**PRINTED CIRCUIT SPEED CONTROLS.** Designed for Electric cars but also suitable for boats, etc. Rated at 6 Amp continuous with temporary overloads up to 10 Amp. Fully proportional forward and reverse. Ideal for standard 'Cyclone', **£3.00** p&P 20p.

'**CYCLONE**' type motors as fitted to 'Electra Car' Bolink, etc., only **£2.99** each, p&P 35p.

'**RED SPOT CYCLONE**' — hotter than standard, very 'Hairy' performance, taking 2 amps more at stall than standard. If you can handle the speed, still competitively priced at **£3.45** p&P 35p.

**NICADS** at sensible prices. Not to be confused with standard types these are **FAST CHARGE**. 1.2 Amp hour 1.2 volt. **£1.45** each, p&P 10p each.

**STOCKER SUPER STAR 1977 COMPETITION.** December 27th, 1977 at the Newbridge circuit, Leicestershire: 30 entrants only; 5 heats x 6 cars. **ENTRANCE FEE £1.50. FIRST PRIZE £25.00** voucher plus Cup; Second Prize £10.00 voucher plus plaque; Third Prize £5.00 voucher plus badge. R.S.C.A. rules to apply. **OPEN CONCOURS COMPETITION** prior to racing — Prize £5.00 plus plaque. **TELEPHONE APPLICATION PLEASE.**

### SUBSCRIPTION ORDER FORM

I hope you will be able to persuade your local model shop to carry supplies of **RADIO CONTROL MODEL CARS**: but, if not, I shall be delighted to supply monthly on request or enrol you for an annual subscription, that is six copies a year.

**RADIO CONTROL MODEL CARS** will appear approximately every other month — September: November: January: March: May: July. Six issues starting with No. 3... £3.50.

If you have missed Issue No. 1 and want a complete run of the magazine this can still be done, which means you have one back issue and five forward issues... same price of £3.50.

Fill in coupon below (or use plain paper if you do not wish to cut magazine).

Name .....  
(Block Letters Please)

Address .....

Post Code .....  
(PO/Cheque/IMMO £3.50 herewith)

Starting with Issue No. ....  
Please send Issue No. 1 (delete as necessary).  
**SUBSCRIPTION ACKNOWLEDGMENT** will be included with your first subscription issue. Renewal reminder will come with last issue but one.

Send to: **L-D EDITORIAL & TECHNICAL SERVICES LTD.**, Post Office Box No 30, **HEMEL HEMPSTEAD HERTS. HP1 1NL.**

Reg. Office 17 Vicarage Close, Hemel Hempstead.  
Reg. England 1291923

## "SMOOTH-TRONIC"

Electric Car Speed Controller with Proportional Throttle and Proportional Dynamic Braking

**VERY WIDE RANGE OF ENGINE SPEEDS** — for precise control over all manoeuvres (e.g., smooth handling through corners). **FULLY PROPORTIONAL DYNAMIC BRAKING** — giving a smooth transition from full power, down through "neutral" to maximum braking. **PLUGS DIRECTLY INTO RECEIVER** (positive 1 m/s-2 m/s) — for elimination of servo, push rods, complicated wiring, unreliable switches and hot resistors. **PERSONALISING ADJUSTMENT** — The position of the TX stick at full throttle, neutral and braking is pre-set by 2 small adjustments. **SMALL SIZE** — (1.6 x 2.4 x 0.9 in.) — for quick and easy installation. **LIGHTWEIGHT** (2 oz.) — for maximum acceleration. **HIGH POWER CAPACITY** — for 7.2 volts, 12 amps (25 amps peak). **ONLY 0.2 VOLT DROP AT FULL POWER** — ensuring no reduction in performance in acceleration and top speed. **LOW POWER CONSUMPTION** — for very cool running, and more power available at the wheels towards the end of the race.

**PRICE: £19.50, inclusive (£20.50, overseas)**

Send cheque or postal order to:

**I & D ELECTRONIC CO.**  
46 Church Road, Barnes, London SW13, England

(Trade enquiries welcomed.)

# R/C CARS IN TRANSVAAL



Two S. Africa entries in California. Left: John Pretorius ran in C Main (26th overall) and Bob Reid 72nd. Good show for a start!

Dear Dickie,

On reading the August copy of R.C.M. & E. I noticed your announcement in connection with a new Mag — solely for R.C. Cars. I have taken the liberty of writing an article regarding the activities in South Africa. As will be seen nothing is National at present so I have written mainly about our own Club activities.

I hope that I can make this a regular monthly contribution and would welcome any comments you have in this regard.

Thanking you,

Yours sincerely,

**JEFF BARCLAY,**  
Chairman.

THE SPORT of R.C. Car Racing started in South Africa about 7 years ago and until recently seemed to go in fits and starts. In October 1976 a group of enthusiasts got together and formed the Transvaal Radio Auto Club — known as T.R.A.C. This Club started with 9 Members and now only 9 months later boasts a membership of over 30 with approximately 24 active drivers. Racing is held on the Club's track which is in the grounds of a Drive-In Cinema at Benoni which is in the Johannesburg area. At this time the main interest is centred around Johannesburg and Benoni but moves are underway to make contact with Clubs in other main centres and then to form a National controlling body.

So much for the background. T.R.A.C. is now almost three quarters way through the championship series for 1977 and the last Meeting was held on Sunday, the 31st July at which we had the pleasure of having Chris Pettit — the Chairman of the Maidenhead Model Maker Club, London, participating. Chris had a very good day considering he was driving a strange car with a motor more powerful than he had used before. Although he did not make the Main Grand Prix he finished a very strong 4th against some of our top drivers in the Consolation G.P. Positions for these G.P.'s. is determined by your points scored in the morning's Sprint Races. Chris finished in 11th place out of a field of 18. As Chairman of T.R.A.C. I would like to say it was great having him with us and hope to see more Drivers in the future.

Our system of racing is that we run a series of sprint races during the morning

on which each driver scores points. A maximum of six Drivers are allowed in each sprint race and each driver will run in 5 races. A points scoring system of 9-6-4-3-2-1 is used so each driver scores points to a maximum of 45. The grid positions for the main and consolation G.P.'s are worked out on this basis. The top ten drivers going into the main G.P. The championship positions are based on the above mentioned scoring system.

Our cars are mainly Associated or Scratch built although 3 P.B. Kits have just arrived on the scene and a few more are in the process of being built. These Kits are an ideal way to start as they are very strong and can take a considerable amount of punishment before showing signs of damage. Most of the chaps are using **VECO** or **VECO MC**. **COY** Engines all in various stages of tune but the more potent **K & B 21** and **SUPER TIGRE X 21** Motors are starting to make their appearance. This mixture makes for some very close and exciting racing.

### CHRIST PETTIT FOOTNOTE:

On holiday in Johannesburg I took my much modified Mardave Lola car, at the invitation of Jeff Barclay and the other members of the club. Their track is situated at one of the local drive-in cinemas and the surface is a fairly high traction asphalt, although the winter dust can cause entertaining moments. The track itself is of clever design incorporating three right-angled corners, a 'Z' bend chicane and a long curve at the end of a long straight which continually tightens up as it is negotiated. I would like to thank all the members of T.R.A.C. for the friendliness and helpfulness which seems to be an integral part of the club. Thanks fellas, it was a memorable day.

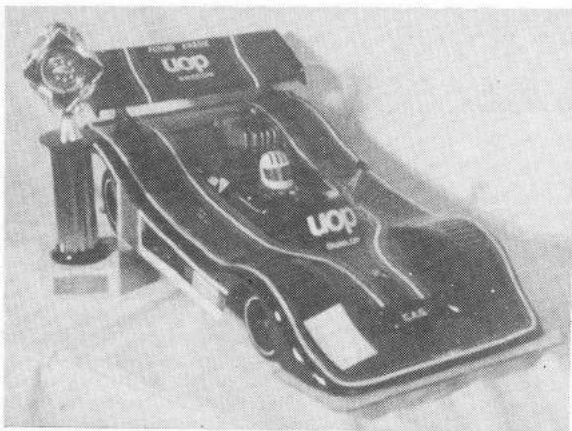

*Mick Doughty's pinstriped and detailed Shadow was winner of Concours d'Elegance.*

**STEWART  
BUSBY  
OF  
THE MARDAVE  
OWNERS' CLUB  
PRESENTS**

## THE NEWBRIDGE SCENE..

FIRST a few notes on the formula to which races at Newbridge are run. The Mardave Owners Club, guided by Wes Rayner, believe that everyone likes to win but that not everyone can or is willing to buy expensive new machinery. So therefore to cater for everyone a three class system was introduced, A, B, C (Open) and these three classes are run on the following guide lines.

### Class A

The cost of the car, engine and all accessories, as raced, but excluding radio equipment, shall not exceed £60 at retail prices current on December 1st, 1976. Cars may be built from kits or scratch-built, but the entrant must be prepared to declare the cost of his car, and, if challenged, must be able to account for the cost of proprietary parts and to produce replicas of scratchbuilt parts for the declared cost.

### Class B

As Class A, but maximum cost of £90.

### Class C (Open)

Unlimited cost.

All classes to comply with BRCA construction rules. As can be seen from the above there is plenty of scope for experimenting with one's own ideas and for the fitting of commercially available parts in the A and B classes. Drivers in each class have three five minute races and their best two lap scores are counted. This gives everyone the chance to overcome at least one bad or unlucky run! Five minute finals are then held for each class and a trophy

awarded to the winner.

It can, and does, happen that a Class A driver also qualifies for the B Class final and a Class B driver for the Open final due to the fact that they have a higher total of laps than some of the higher class drivers. In fact it has happened this season that a Class A driver has qualified for all three finals.

This system operates at all our F1/Sports meetings and also the saloon meetings which we hold in conjunction with novice racers, for which everyone who has not won a trophy is eligible. Points are scored in the Class A and B finals, on a 9-6-4-3-2-1 basis. The best four scores from the five F1/Sports and the best three from the four saloon meetings being held this year go towards the club's championship trophies presented by Waltron, Small Parts, Mardave, Veco and Wyvern Tubes.

### AUGUST 21st F1/SPORTS MEETING

Sunday, August 21st dawned a dry and sunny day — what a pity it didn't stay that way! The first round of heats were run in near perfect conditions and several drivers produced runs of 23 laps. The second round was a different story, however, for just as it began the rain came down and made the track into a real skid pan. Many drivers hurriedly changed to capped tyres but even with these it was necessary to have a gentle throttle hand, and coupled with the understeering characteristics of these tyres scores were down by an average of eight laps. Halfway through the

second round the sun came out again and by the beginning of the third round the track was dry. This round as it turned out decided the winners of the F1 trophies as at the end it poured with rain again and it was decided to award the first six places in the A and B class on heat laps instead of finals.

Class A	Class B
1 Tony Bicknell	1 Stew Busby
2 Fred Mason	2 Mick Doughty
3 Steve Cox	3 John Elliott
4 Sandie Mellors	4 Keith Payne
5 Les Wormald	5 Paul Mason
6 Harry Mason	6 Steve Mellors

If the weather situation had been known perhaps everyone would have tried that little bit harder as in the end only one lap separated the first three drivers. Sandie Mellors by the way is our regular lady driver and with her husband Steve is becoming quite a force on the track. The hoped for battle of the six-wheelers, Des Norton's Elf Tyrrell and Stew Busby's March, never materialised as Des had handling problems in practice and raced his Lotus 78 in the meeting — but he promises us that after further development he will be racing the Tyrrell at the next F1 meeting on September 18th.

The sports GT heats in the afternoon were all raced in the same conditions — wet! During the heats there was some notably good steady driving by some relatively newcomers to the hobby. Alan

Blakeman, John Darrington, Harry Mason and eleven year old Andrew Elliott all showed some of the more experienced drivers how it should be done on a wet track.

Top qualifier for the A class final was Tony Bicknell on 32 laps and joint top qualifiers for the B class final were Stew Busby and Mick Doughty on 34 laps. The A class final saw a close race between Alan Blakeman and John Darrington who both finished on 15 laps but Alan being ahead at the end was awarded first place. Alan also qualified for the B Class final and finished a very creditable third behind winner Mick Doughty and second man Paul Mason. The other three finalists had engine problems and had a very frustrating final.

Class A	Class B
1 Alan Blakeman	1 Mick Doughty
2 John Darrington	2 Paul Mason
3 Harry Mason	3 Alan Blakeman
4 Sandie Mellors	4 Harry Mason
5 Tony Bicknell	5 Stew Busby
6 Andrew Elliott	6 Tony Bicknell

(As all the cars entered at this meeting came into the A and B classes no finals were held for the Open Class).

Some observations from this rather wet meeting — the first we've had at Newbridge for about two years (!!!) Caps, i.e.,

*Two of the Mardave Owners' Club Tyrrells pictured earlier in the season at Lifford Park.*

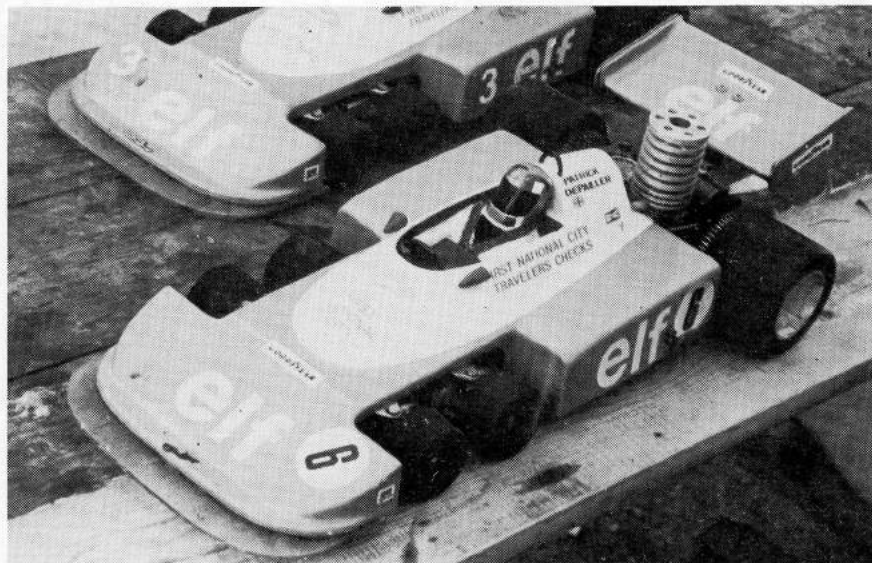

motor cycle inner tubing stretched and glued over at least the rear tyres were a must to prevent too much spinning out. Adhesive tape round radio box joints and Vaseline on all areas where it is possible water might get to the radio is useful — it's messy to clean off but can save your radio gear and possibly the race as well. Also useful is a suitable cover that fits over and around the carb filter, leaving just enough room for air to reach the carb but not any water which may get splashed about. This seems especially needed on carbs using foam as a filter material. Such a cover can be shaped from tinplate and soldered together.

Prior to the racing the cars were lined up to be judged in a Concours d'Elegance competition. Dave Beatty, Steve Cox, Carol Gough, Mick Doughty, Steve Mellors, Tony Bicknell and Andrew Elliott all had some striking paintwork on their cars. Mick Doughty was awarded first place for his beautifully pin-stripped and detailed Shadow GT and young Andrew Elliott awarded a special junior award for his nicely prepared and matching FL and Sports/GT bodies.

## MICHAEL'S MODELS

646—648 HIGH ROAD  
N. FINCHLEY N12 0NL

Telephone 01-445-6531

**CAR KITS** by MARDAVE  
P.B. KE'JON, LECTRICAR  
**ENGINES** by Super Tigre  
O.P.S., K. & B., VECO, ENYA

### STOCK CARS

KE'JON	£29.95
MARDAVE	£21.50
SLIDE CARB FITS	
K. & B. 21	£14.00
P.B. INTERNATIONAL KIT	£75.00

PHONE YOUR CREDIT CARD NUMBER  
FOR SAME DAY SERVICE  
ACCESS BARCLAYCARD CARTE BLEU  
EUROCARD MASTERCARD VISA  
BANK AMERICA CARD

# STAY AWAY FROM R/C CARS

They are contagious . . . This terrible disease was brought to the Thames Valley area, nearly two years ago, by one Christopher Pettit defying quarantine after a visit to South Africa. M.R.M. immediately realised the significance of the problem and set up a unit to combat it. R/C cars usually only affects the male population but it is not unknown for females to be similarly affected. Our first course of action, after watching the unfortunate Pettit having his symptomatic convulsions in a local school playground, was to lay in a stock of the wonder drug, Mardave. This proved to be useless due to its being highly addictive, seizures were not uncommon. As the disease spread patients very often became violent during periods of delivery delay. The situation rapidly developed into an epidemic and isolation was the only chance for public survival. A leper colony was formed at a local airfield where the disease mutated into yet more terrifying afflictions, namely, Essangeemotosis, Deltaree and the Associated complaints of Expertigite and Internationalitus (Known as the Pee-Bees). M.R.M. has continued to serve the needs of all unfortunates that come our way, using the most advanced techniques known to science. Those still in the incubation period can normally be cured by a quick dose of aeromodelling but more advanced cases require a long course of suitable advice and a plentiful supply of spares, you, the public can help by sending anyone suspected of being contaminated by an R/C car to M.R.M. where he or she will be assured of sympathetic help and understanding and may one day be returned to society a complete human being.

Be warned! . . . Stay away from R/C cars. If you ever touch one then go immediately to your nearest Woolworths and have a good rub down with an Airfix kit. It's your only chance!

## MAIDENHEAD RADIO MODELS

55 QUEEN ST., MAIDENHEAD, BERKS.



37295

Surgery Hours: 9—5.30 Mon., Tues., Wed. Closed Thurs. 9—7.00 Fri.  
9—5 Sat. SAE with all enquiries. Parking outside.

0628



## RACING

FRANCO SABATTINI European Champion '74 and Designer of European Championship winner driven by Ronnie Ton has kitted his current designs in two versions — the Professional and Expert — both designs come assembled and include all-ballrace transmission and wheel bearings. Clutch units for X21 Super Tigre or other 1/4 in UNF. Shafts provided. A range of LEXAN bodies are also available.

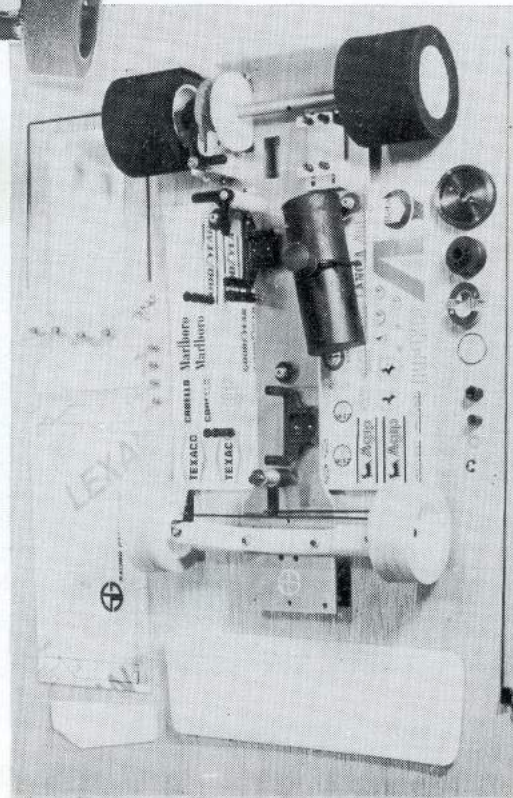
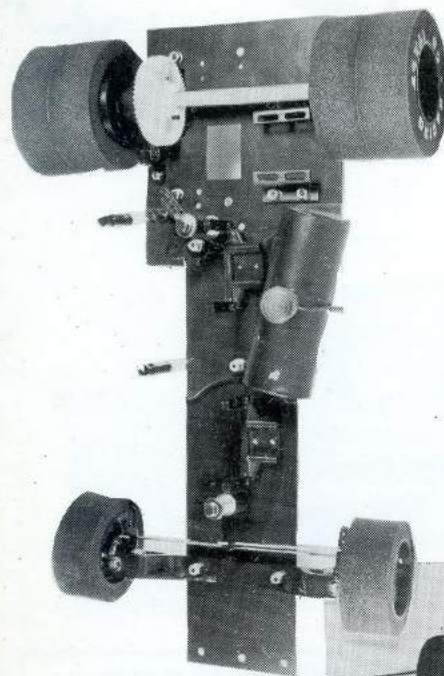

### PRICES:

SG EXPERT . . . . . £124.55 inc. VAT  
SG PROFESSIONAL . . . . . £66.72 inc. VAT  
LEXAN BODIES . . . . . £5.31 inc. VAT

Expert series has disc brake, Lexan rear wing and support, nylon axle assembly, driver, tank, receiver aerial and transfers. Professional series has friction band brake, adjustable motor mount, Lexan bumpers, body supports and transfers.

# WORLD ENGINES LTD

97 Tudor Avenue, Watford, Herts. Phone: Watford 42289

SAE with enquiries requiring reply.  
Available from the Nation's best model shops.



**PB PRODUCTS**

**'Expert'**  
SERIES



## **PB INTERNATIONAL KIT**

is the Experts' Choice. EVERY MAJOR EVENT in the BRCA 1977 RACING CALENDAR to date has been won with a PB INTERNATIONAL Car.

### **1/12 SCALE ELECTRIC**

Good news for electric car racing! PB are now importing famous MRP ready to run electric cars (just fit the radio). Fast, elegant, proportional speed control.

### **MRP in GB from PB**

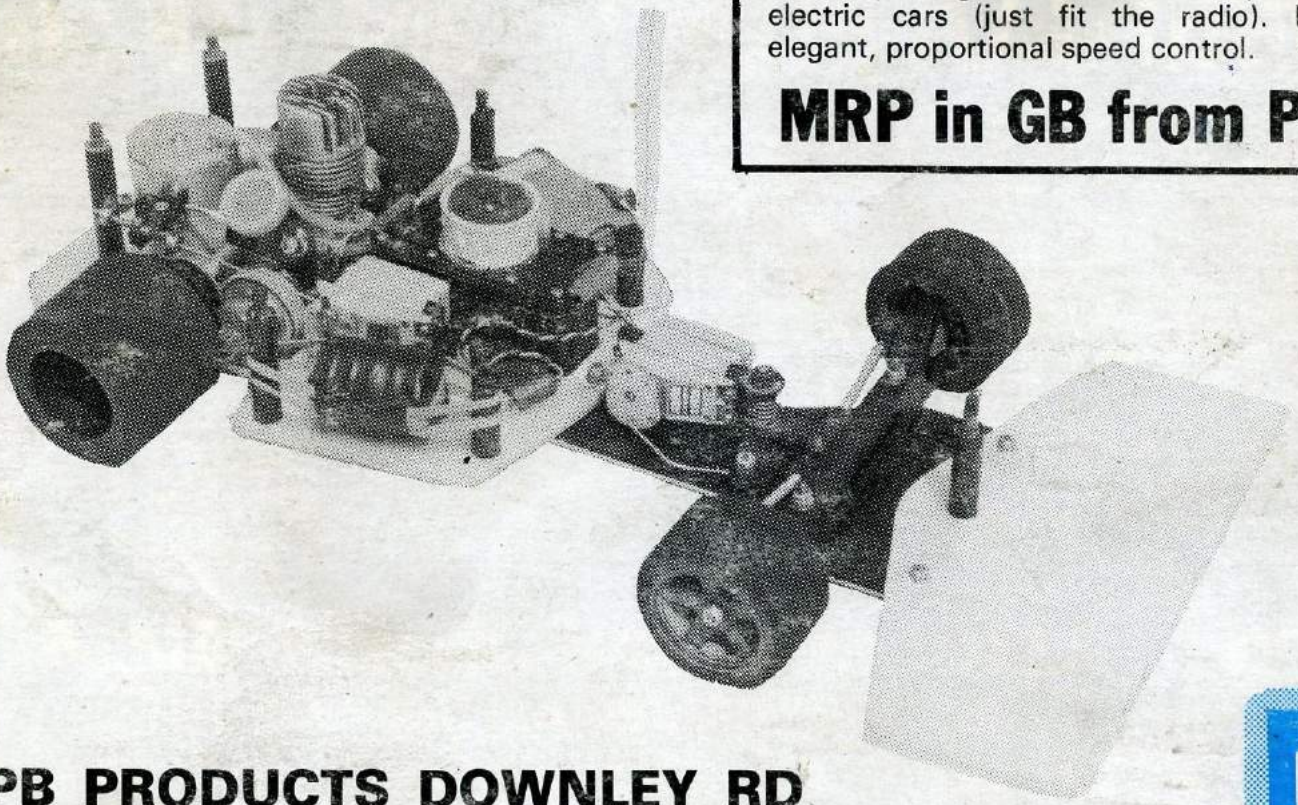

**PB PRODUCTS DOWNLEY RD  
HAVANT HANTS**

**Tel. HAVANT 71774**

